

THERE ARE MORE CESSNAS FLYING THAN ANY OTHER MAKE

CESSNA

"TAKE YOUR CESSNA HOME
FOR SERVICE AT THE SIGN
OF THE CESSNA SHIELD".

CESSNA AIRCRAFT COMPANY
WICHITA, KANSAS

1965
CESSNA

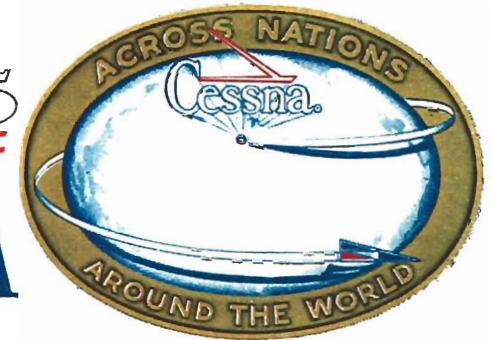

MODEL
310 J

**OWNER'S
MANUAL**

WORLD'S LARGEST PRODUCER OF GENERAL AVIATION AIRCRAFT SINCE 1956

PERFORMANCE AND SPECIFICATIONS.

GROSS WEIGHT	5100 lbs.
SPEED: BEST POWER MIXTURE	
Maximum at Sea Level	238 mph
Maximum Recommended Cruise	
75% Power at 6500 ft.	223 mph
RANGE: NORMAL LEAN MIXTURE	
Maximum Recommended Cruise	
75% Power at 6500 ft.	780 mi.
100 Gallons, No Reserve	3.5 hrs.
	221 mph.
75% Power at 6500 ft.	1015 mi.
130 Gallons, No Reserve	4.6 hrs.
	221 mph.
Maximum Range at 10,000 ft.	
100 Gallons, No Reserve	980 mi.
	5.5 hrs.
	180 mph.
	1270 mi.
130 Gallons, No Reserve	7.1 hrs.
	180 mph.
RATE OF CLIMB AT SEA LEVEL:	
Twin Engine	1590 fpm.
Single Engine	360 fpm.
SERVICE CEILING:	
Twin Engine	20,300 ft.
* Single Engine	7500 ft.
TAKE-OFF PERFORMANCE: Take-off Speed 85 MPH (Vmc)	
Ground Run	1385 ft.
Total Distance over 50 ft. obstacle	1640 ft.
LANDING PERFORMANCE: Approach Speed (100 MPH)	
Landing Roll	960 ft.
Total Distance over 50 ft. obstacle	1540 ft.
EMPTY WEIGHT (Approximate)	3094 lbs.
BAGGAGE ALLOWANCE:	600 lbs.
WING LOADING:	29.1 lbs./sq. ft.
POWER LOADING:	9.8 lbs./hp.
FUEL CAPACITY: Total	
Standard	102 gal.
Optional Auxiliary Tanks	133 gal.
Optional Auxiliary and Wing Locker Tanks	173 gal.
OIL CAPACITY: Total	6 gal.
POWER: Two Continental 6-Cylinders, Fuel Injection IO-470-U Engines, 260 rated Horsepower at 2625 rpm	
PROPELLER: Constant Speed, Full Feathering, Dia.	81 inches

* Single-Engine Service Ceiling increases 425 feet each 30 minutes of flight.

SERVICING REQUIREMENTS



FUEL:

AVIATION GRADE - 100/130 MINIMUM
 CAPACITY EACH MAIN TANK - 51 GALLONS
 CAPACITY EACH AUXILIARY TANK - 15.5 GALLONS
 CAPACITY EACH WING LOCKER TANK -- 20.5 GALLONS

ENGINE OIL:

AVIATION GRADE -- SAE 30 OR SAE 10W30 BELOW 40°F
 SAE 50 ABOVE 40°F

(MULTI-VISCOSITY OIL WITH A RANGE OF SAE 10W30 IS RECOMMENDED FOR IMPROVED STARTING IN COLD WEATHER. DETERGENT OR DISPERSANT OIL CONFORMING TO CONTINENTAL MOTORS SPECIFICATION MHS-24A MUST BE USED. THE AIRCRAFT IS DELIVERED FROM THE FACTORY WITH STRAIGHT MINERAL OIL.)

CAPACITY EACH ENGINE SUMP -- 12 QUARTS

(DO NOT OPERATE ON LESS THAN 9 QUARTS, FILL TO 10 QUART LEVEL FOR NORMAL FLIGHTS OF LESS THAN 3 HOURS, AND FILL TO CAPACITY IF EXTENDED FLIGHT IS PLANNED. IF OPTIONAL OIL FILTER IS INSTALLED, ONE ADDITIONAL QUART IS REQUIRED WHEN THE FILTER ELEMENT IS CHANGED.)

OPTIONAL OIL FILTER ELEMENT -- CESSNA 1250406-2

HYDRAULIC FLUID: MIL-H-5606 HYDRAULIC FLUID (RED)

PROPELLER GREASE: MIL-G-3278 GREASE

OXYGEN:

AVIATOR'S BREATHING OXYGEN -- MIL-O-27210
 MAXIMUM PRESSURE -- 1800 PSI

TIRE PRESSURE:

MAIN WHEELS -- 60 PSI
 NOSE WHEEL -- 24 PSI

VACUUM AIR FILTER:

ELEMENT -- C294501-0103

WARRANTY

■ The Cessna Aircraft Company (Cessna) warrants each new aircraft, including factory installed equipment and accessories, and warrants all new aircraft equipment and accessories bearing the name "Cessna", to be free from defects in material and workmanship under normal use and service. Cessna's obligation under this warranty is limited to supplying a part or parts to replace any part or parts which, within six (6) months after delivery of such aircraft or such aircraft equipment or accessories to the original retail purchaser or first user, shall be returned transportation charges prepaid to Cessna at Wichita, Kansas, or such other place as Cessna may designate and which upon examination shall disclose to Cessna's satisfaction to have been thus defective.

■ The provisions of this warranty shall not apply to any aircraft, equipment or accessories which have been subject to misuse, negligence or accident, or which shall have been repaired or altered outside of Cessna's factory in any way so as in the judgment of Cessna to affect adversely its performance, stability or reliability. This warranty is expressly in lieu of any other warranties, expressed or implied, including any implied warranty of merchantability or fitness for a particular purpose, and of any other obligation or liability on the part of Cessna of any nature whatsoever and Cessna neither assumes nor authorizes anyone to assume for it any other obligation or liability in connection with such aircraft, equipment and accessories.

CONGRATULATIONS.....

Welcome to the ranks of Cessna owners! Your Cessna Model 310 has been designed and constructed to give you the most in performance, economy, and comfort. It is our desire that you will find flying it, either for business or pleasure, a pleasant and profitable experience.

This Owner's Manual has been prepared as a guide to help you get the most pleasure and utility from your Model 310. It contains information about your Cessna's equipment, operating procedures, and performance; and suggestions for its servicing and care. We urge you to read it from cover to cover, and to refer to it frequently.

Our interest in your flying pleasure has not ceased with your purchase of a Cessna. World-wide, the Cessna Dealer Organization backed by the Cessna Service Department stands ready to serve you. The following services are offered by most Cessna Dealers:

FACTORY TRAINED PERSONNEL to provide you with courteous expert service.

FACTORY APPROVED SERVICE EQUIPMENT to provide you with the most efficient and accurate workmanship possible.

A STOCK OF GENUINE CESSNA SERVICE PARTS on hand when you need them.

THE LATEST AUTHORITATIVE INFORMATION FOR SERVICING CESSNA AIRPLANES, since Cessna Dealers have all of the Service Manuals and Parts Catalogs, kept current by Service Letters and Service News Letters published by Cessna Aircraft Company.

We urge all Cessna owners to use the Cessna Dealer Organization to the fullest.

A current Cessna Dealer Directory accompanies your new airplane. The directory is revised frequently, and a current copy can be obtained from your Cessna Dealer. Make your Directory one of your cross-country flight planning aids; a warm welcome awaits you at every Cessna Dealer.

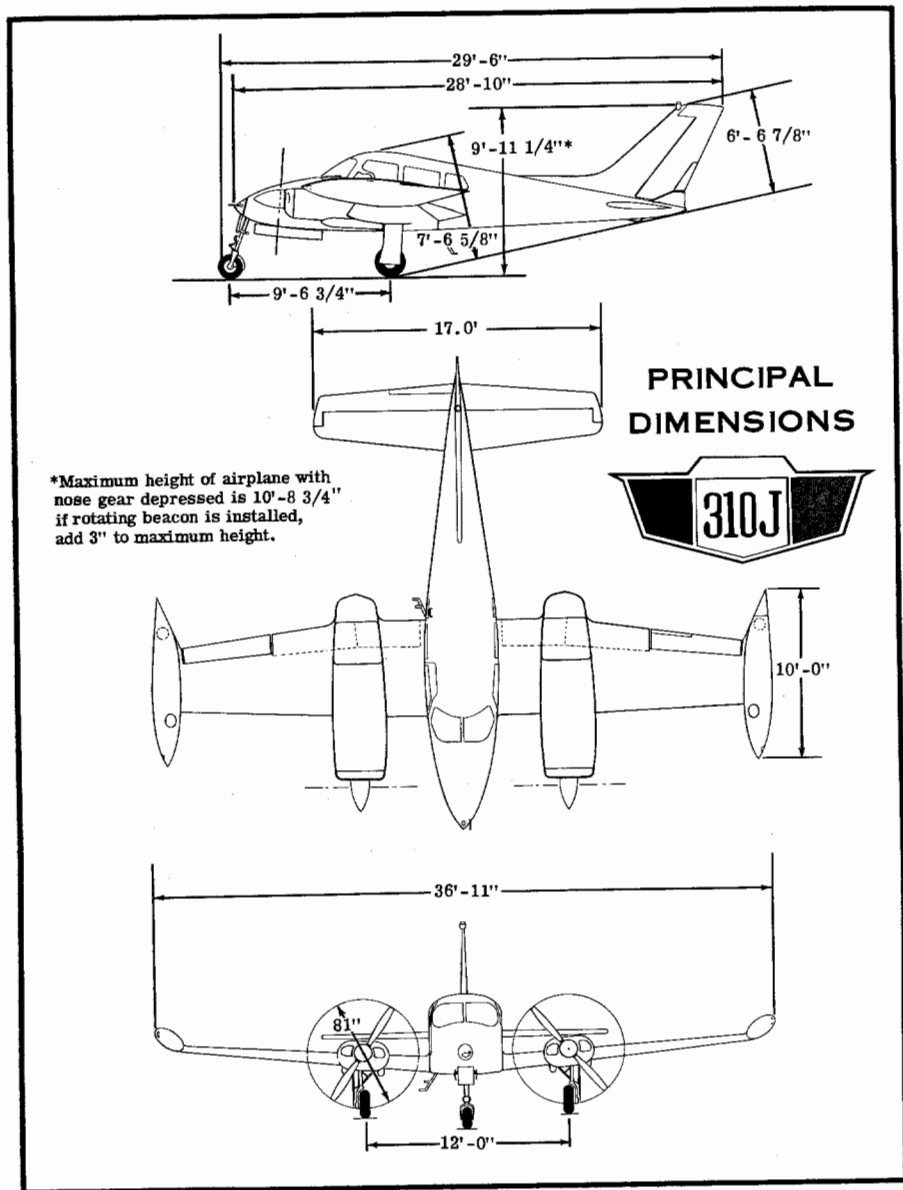

Loss) 3-8

Forced (Precautionary Landing with Power) 3-7

Gear Handcrank 2-4

Gear System 2-3, 3-9

Single-Engine. 3-7

Letdown 1-5

Loading Chart 4-5

Lockers, Wing 4-3

Lubrication and Servicing Procedures 5-6

M

Maneuvers - Normal Category 4-1

Manifold Pressure 4-2

Maximum Glide 3-6

Maximum Performance

 Climb 1-4

 Takeoff 1-3

Mooring your Airplane 5-1

O

Oil Dilution System 7-3

Operations Authorized 4-1

Operation Limitations, Engine 4-2

Overheat Warning Light 2-5

Owner Follow-Up 5-4

Oxygen-Altitude Consumption Rate Chart 7-2

Oxygen System 7-1

P

Problem, Sample 4-4

Propeller Care 5-3

R

Restarting Engine in Flight (After Feathering) 3-5

S

Sample Problem 4-4

Service, Inspection and Inspection Periods 5-3

Single-Engine

 Airspeed Nomenclature 3-2

 Approach 3-7

 Climb Data 6-6

 Landing 3-7

 Takeoff 3-3

 Takeoff Distance 6-5

Spins 2-10

Stall 2-9

Stall Speed Chart 6-2

Starting Engines 2-5

Starting Engines (Left Engine First). 1-2

Static-Pressure, Alternate-Source Valve 2-5

Supplementary Information Concerning Engine-Out During Takeoff 3-2

Switches

 Auxiliary Fuel Pump 2-1

 Battery and Generator. 2-3

T

Tachometer 4-3

Takeoff 1-3, 2-7

 Before 1-2, 2-7

 Maximum Performance 1-3

 Normal 1-3

 Single-Engine 3-3

Taxiing 2-6

V

Ventilation, Heater Used for 2-5

W

Weight and Balance 4-3

Windows and Windshields. 5-2

Wing Lockers 4-3

 Fuel System 7-8

Before Entering Airplane	7-6	Fire Detection and Extinguishing System	7-8
Operating Details	7-7	Flat Main Gear Tire, Landing with	3-9
Dilution System, Oil	7-3	Flyable Storage	5-7
Dimensions, Principle	ii	Forced Landing Complete Power Loss	3-8
Ditching	3-12	Precautionary Landing with Power	3-7
Drains, Fuel Strainer and Tank Sump	2-1	Fuel Flow Gage	4-3
E		System	2-1, 3-8, 7-8
Electrical System	2-1	G	
Emergencies Landing	3-9	Gages Fuel Flow	4-3
Defective Main Gear	3-11	Oil Temperature	4-2
Defective Nose Gear	3-11	Oil Pressure	4-2
Flat Main Gear Tire	3-9	Generator and Battery Switches	2-3
Flat Nose Gear Tire	3-10	Ground Handling	5-1
Smooth Hard Surface Runway-Main Gear Extended	3-12	H	
Sod Runway-Main Gear Retracted	3-11	Handcrank, Landing Gear	2-4
Engine Instrument Markings	4-2	Handling, Ground	5-1
Operation Limitations	4-2	Heater System	2-4
Restarts in Flight (After Feathering)	3-5	I	
Engine-Out Procedures	3-1	Inspection, Exterior	iv
After Takeoff, Above 102 MPH (without sufficient runway ahead)	3-1	Interior Care	5-3
During Flight	3-5	Instrument Markings, Engine	4-2
During Takeoff, Supplementary Information	3-2	Fuel Flow Gage	4-3
On Takeoff (with sufficient runway remaining)	3-1	Cylinder Head Temperature	4-2
Engines Before Starting	1-1	Manifold Pressure	4-2
Starting	2-5	Oil Pressure Gages	4-2
Starting (Left Engine First)	1-2	Oil Temperature Gages	4-2
Equipment, Cold Weather	7-3	Tachometer	4-3
Exterior Inspection	iv	L	
F		Landing	1-5
File, Airplane	5-5	After	1-5, 7-6
		Before	1-5
		Forced (Complete Power)	

TABLE OF CONTENTS



Page

SECTION I	- OPERATING CHECKLIST	1-1
SECTION II	- DESCRIPTION AND OPERATING DETAILS	2-1
SECTION III	- EMERGENCY PROCEDURES.....	3-1
SECTION IV	- OPERATING LIMITATIONS.....	4-1
SECTION V	- CARE OF THE AIRPLANE.....	5-1
	OWNER FOLLOW-UP SYSTEM	5-4
SECTION VI	- OPERATIONAL DATA.....	6-1
SECTION VII	- OPTIONAL SYSTEMS.....	7-1
ALPHABETICAL INDEX.....	Index - 1	

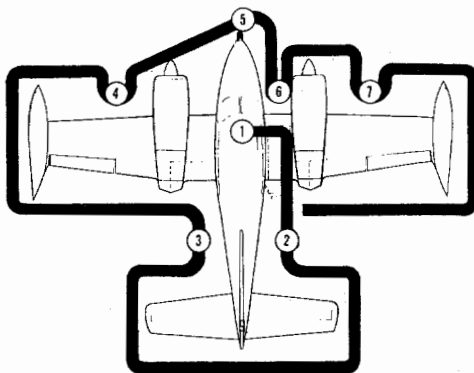

EXTERIOR INSPECTION

NOTE

Check general aircraft condition during walk-around inspection. If night flight is planned, check operation of all lights; make sure a flashlight is available.

1. Check wing locker fuel tank vent for obstructions, if installed.
 - j. Check wing locker fuel tank cap for security, if installed.
 - k. On first flight of the day and after each refueling, drain small amount of fuel from quick-drain valve in the auxiliary tank and wing locker fuel transfer line, if installed.
 - l. Check battery drain and battery compartment cover panel for security (left side only).
 - m. Remove wing tie-down.
2. a. Check oil level. (Do not operate on less than 9 quarts. Fill to 10 quart level for flights of less than 3 hours. Fill to capacity for extended flights.) Check dip stick for security and engine compartment for general condition.
 - b. Check oil filler cap for security through oil filler access door.
 - c. Check main landing gear strut and tire inflation. Check gear doors for security.
 - d. On first flight of day and after each refueling, drain about two ounces of fuel from fuel strainer to clear of any water and sediment.
 - e. Check propeller and spinner for nicks, cracks and security and propeller for oil leaks.
 - f. Check cowl access doors for security.
3. a. Check left nose access panel for security.
 - b. Check nose gear strut and tire inflation; check nose gear doors for security.
 - c. Remove tie-down, if installed.
 - d. Check right nose access panel for security.
 - e. Remove pitot tube cover, if installed, and check pitot tube opening for obstructions.
 - f. Check heater inlet for obstructions.
4. a. Same as 4.
 7. a. Same as 3 except in reverse order.
1. a. Turn on battery switch. Check fuel quantity gages, check operation of stall warning transmitter tab and horn by raising tab on left wing, and check main tank transfer pumps for operation (listen for audible clicking emanating from main tanks). Turn battery switch OFF.
 - b. Check landing gear switch DOWN.
 - c. Check magneto switches OFF.
 - d. Check left fuel selector in LEFT MAIN position and right fuel selector in RIGHT MAIN position (feel for detent).
 - e. Check oxygen knob - PULL ON.
 - f. Check oxygen pressure.
 - g. Remove control lock.
2. a. Open baggage door and check that oxygen masks and hoses are available.
 - b. Close baggage door and check for security.
 - c. Check static pressure source holes for obstruction (both sides of fuselage).
 - d. Remove control surface locks, if installed.
 - e. Remove tie-down.
3. a. Check wing locker door for security.
 - b. On first flight of the day and after each refueling, drain small amount of fuel from quick-drain valve in the wing locker fuel tank, if installed.
 - c. Remove control surface lock, if installed.
 - d. Check snaffle valve opening for obstruction.
 - e. Check main fuel tank vent for obstructions (especially water and ice accumulation in the tank vent shield during cold weather operation).
 - f. Check main fuel tank cap for security.
 - g. On first flight of the day and after each refueling, drain small amount of fuel from quick-drain valve in the main tank.
 - h. Check auxiliary fuel tank cap for security.

Figure 1-1.



ALPHABETICAL INDEX

	Page
	Inspection Periods 5-3
	Interior 5-3
	Lubrication and Servicing
	Procedures 5-6
	Mooring your Airplane 5-1
	Painted Surfaces 5-2
	Propeller 5-3
	Windows and Windshields 5-2
	Charts
	Accelerate Stop Distance 6-4
	Cruise
	Performance 6-8, 6-9, 6-10
	Landing Performance 6-7
	Loading Chart 4-5
	Maximum Performance
	Takeoff 6-7
	Normal Takeoff Distance 6-3
	Oxygen - Altitude Consumption
	Rate Chart 7-2
	Single-Engine Climb Data 6-6
	Single-Engine Takeoff
	Performance 6-5
	Stall Speed 6-2
	Twin-Engine Climb Data 6-6
	Circuit Breakers 2-3
	Climb 1-4, 2-8
	Normal 1-4
	Maximum Performance 1-4
	Cold Weather Operation 2-10
	Contents, Table of iii
	Cruise 1-4, 2-8
	Performance 6-8, 6-9, 6-10
	Cylinder Head Temperature 4-2
	D
	Deicing System 7-6
A	
After Landing 1-5, 7-6	
Airplane File 5-5	
Airspeed	
Correction Table 6-2	
Nomenclature, Single-Engine 3-2	
Alternate-Source Valve, Static Pressure 2-5	
Anti-Ice System, Propeller	
Emergency Operation 7-5	
Normal Operation 7-4	
Authorized Operations 4-1	
Auxiliary Fuel Pump Switches 2-1	
Auxiliary Fuel System 7-1	
B	
Battery and Generator	
Switches 2-3	
Before Landing 1-5	
Before Takeoff 1-2, 2-7	
Before Starting Engines 1-1	
Breakers, Circuit 2-3	
C	
Care of the Airplane 5-1	
Airplane File 5-5	
Deicer Boot 7-7	
Exterior Inspection iv	
Ground Handling 5-1	
Inspection Service and	

- (3) Land as soon as practical.

NOTE

Better results may be obtained if the airflow through the nacelle is reduced by slowing the aircraft (as slow as practical) prior to actuating the extinguisher.

SERVICING

The system should be checked each 100 hours or annual inspection, whichever occurs first.

Check the pressure gage on each bottle to ensure the following pressures:

PRESSURE TEMPERATURE CORRECTION TABLE										
Temp F°	-60	-40	-20	0	+20	+40	+60	+80	+100	+120
Gage	110	127	148	174	207	249	304	367	442	532
Actual	134	155	180	212	251	299	354	417	492	582

If these pressure are not indicated, have the bottle serviced.



SECTION I OPERATING CHECKLIST

One of the first steps in obtaining the utmost performance, service, and flying enjoyment from your Cessna Model 310 is to familiarize yourself with your airplane's equipment, systems, and controls. This can best be done by reviewing this equipment while sitting in the airplane. Those items whose function and operation are not obvious are covered in Section II.

Section I lists, in Pilot's Checklist form the steps necessary to operate your airplane efficiently and safely. It covers briefly all the points that you should know concerning the information you need for a typical flight.

The flight and operational characteristics of your airplane are normal in all respects. All controls respond in the normal way within the entire range of operation. All airspeeds mentioned in Sections I and II are indicated airspeeds. Corresponding calibrated speeds may be obtained from the Airspeed Correction Table, Figure 6-1.

MAKE AN EXTERIOR INSPECTION IN ACCORDANCE WITH FIGURE 1-1.

BEFORE STARTING THE ENGINES.

- (1) Seats and Safety Belts -- Adjust and lock.
- (2) Brakes -- Test and set.
- (3) Landing Gear Switch -- Check DOWN.
- (4) Battery Switch -- ON.

NOTE

When using an external power source, do not turn on the battery switch until external power is disconnected, to avoid a weak battery draining off part of the current being supplied by the external source.

- (5) Generator Switches -- ON.

NOTE

If 50 ampere generators are installed, turn on one at a time as the engines are started.

- (6) Landing Gear Lights -- Press to test (check iris - open).
- (7) Fuel Selectors - Left Engine -- LEFT MAIN (feel for detent).
Right Engine -- RIGHT MAIN (feel for detent).
- (8) Trim Controls -- Set.
- (9) Altimeter and Clock -- Set.
- (10) Turn All Radio Switches -- OFF.

STARTING ENGINES (Left Engine First).

- (1) Mixture -- Full Rich.
- (2) Propeller -- High RPM.
- (3) Throttle -- Open 1 inch.
- (4) Magneto Switches -- ON.
- (5) Start Engine.
 - (a) Primer Switch - Left Engine -- LEFT.
Right Engine -- RIGHT.
 - (b) Starter Button -- Press.

NOTE

- If the primer switch is actuated longer than two or three seconds with the engines inoperative on the ground, damage may be incurred to the engine and/or airplane due to excessive fuel accumulation.
- During very hot weather, caution should be exercised to prevent overpriming the engines. If there is an indication of vapor in the fuel system (fluctuating fuel flow) with engines running, place the auxiliary fuel pump switch to the LOW position until the system is purged.

BEFORE TAKEOFF.

- (1) Flight Controls -- Check (free and correct).
- (2) Throttle Settings -- 1700 RPM.
- (3) Engine Instruments -- Check.
- (4) Generators -- Check.
- (5) Magnetos -- Check (50 RPM maximum differential between magnetos).
- (6) Induction Air Heat Source -- Check by noting RPM and manifold pressure drop.
- (7) Propellers -- Check feathering to 1200 RPM; return to high RPM (full forward position).
- (8) Vacuum Source -- Check source and suction (4.75 to 5.25 inches of mercury).

compartments. The amber light E (Figure 7-3) will illuminate after the extinguisher has been discharged and will continue to show empty until a new bottle is installed. The FIRE light will remain illuminated until compartment temperatures cool.

FIRE EXTINGUISHER	Annunciation		
	Legend	Color	Cause of Illumination
	Fire	Red	Fire condition existing in engine compartment
	E	Amber	Fire extinguisher container empty
	OK	Green	Fire cartridge and associated wiring is in operational condition

Figure 7-3

OPERATING CHECKLIST

NORMAL

Before Takeoff

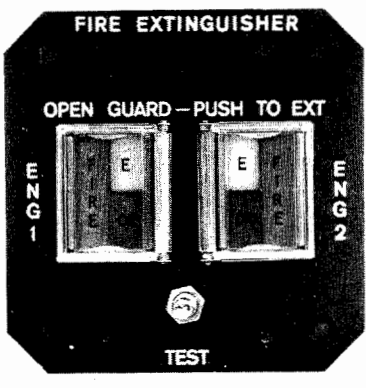
- (1) Press the test switch - all lights should illuminate.

EMERGENCY

If a fire warning light indicates an engine compartment fire and is confirmed or if a fire is observed without a fire warning light:

- (1) Shut down the appropriate engine as follows:
 - (a) Mixture control - IDLE CUT-OFF.
 - (b) Propeller - FEATHER.
 - (c) Magnetos - OFF.
 - (d) Fuel selector - OFF.
 - (e) Cowl flaps - CLOSED.
- (2) Open the appropriate guard and push FIRE light.

SECTION VII

OPTIONAL WING LOCKER FUEL SYSTEM

Optional wing locker fuel tanks (20 U.S. Gallons usable each wing) are installed in the forward portion of the nacelle wing lockers. There are no separate fuel selector controls for the wing locker fuel tanks. The wing locker fuel is pumped directly into the main tanks with a fuel transfer pump. Indicator lights mounted on the instrument panel are illuminated by pressure switches to indicate fuel has been transferred. The wing locker fuel should not be transferred until there is 30 gallons or less in the main fuel tanks to prevent overflow of the main tank fuel. Fuel should be crossed as required to maintain fuel balance after wing locker fuel has been transferred.

NOTE

Wing locker transfer pump switches provided on the instrument panel, energize the wing locker fuel transfer pumps for transferring fuel. These switches should be turned ON only to transfer fuel and turned OFF when the indicator lights come ON indicating fuel has been transferred.

FIRE DETECTION AND EXTINGUISHING SYSTEM

The fire detection and extinguishing system consists of three major components: three heat sensitive detectors located in each engine accessory compartment; an annunciator and actuator panel (see Figure 7-3); and a compressed Freon single shot gas bottle in each engine accessory compartment.

A test function is provided to test the system circuitry. When the test switch is pushed all lights should illuminate, if any light fails to illuminate replace the bulb. If the green light does not illuminate after replacing the bulb, replace firing cartridge in fire extinguisher. Any other light failure, after replacing bulbs and firing cartridge, indicates malfunction in unit or associated wiring.

If an overheat condition is detected, the appropriate FIRE light will annunciate the engine to be extinguished. To activate the extinguisher, open the guard for the appropriate engine and press the FIRE light. Freon, under pressure, will be discharged to the engine and engine accessory

- (9) Oil Temperature -- Check green arc.
- (10) Trim Controls -- Check.
- (11) Cabin Door and Windows -- Closed and locked.
- (12) Flight Instruments and Radios -- Set.
- (13) Auxiliary Fuel Pumps -- ON.

TAKEOFF.

NORMAL TAKEOFF.

- (1) Wing Flaps -- 0°.
- (2) Mixtures -- Lean for field elevation.

NOTE

Leaning during the takeoff roll is normally not necessary; however, should maximum takeoff or subsequent engine-out performance be desired, fuel flow should be adjusted to match field elevation.

- (3) Induction Air -- Check COLD.
- (4) Power -- Full throttle and 2625 RPM.

NOTE

Apply full throttle smoothly to avoid propeller surging.

- (5) Maintain Level Attitude.
- (6) Elevator Control -- Raise nose wheel at 90 MPH.
- (7) Break Ground at 102 MPH.
- (8) Brakes -- Apply momentarily.
- (9) Landing Gear -- Retract.
- (10) Climb Speed -- 124 MPH (best twin-engine rate-of-climb speed).
(Set up climb speed as shown in "NORMAL CLIMB" paragraph.)
- (11) Auxiliary Fuel Pumps -- OFF.

MAXIMUM PERFORMANCE TAKEOFF.

- (1) Wing Flaps -- 15°.
- (2) Power -- Full throttle and 2625 RPM.
- (3) Maintain Level Attitude.
- (4) Elevator Control -- Lift nose wheel at 77 MPH.

- (5) Break Ground at 87 MPH -- Hold speed until all obstacles are cleared.
- (6) Brakes -- Apply momentarily.
- (7) Landing Gear -- Retract.
- (8) Flaps -- Retract (after obstacles are cleared).
- (9) Auxiliary Fuel Pumps -- OFF.

CLIMB.

NORMAL CLIMB.

- (1) Airspeed -- 130 - 160 MPH.
- (2) Power -- 24 inches Hg. and 2450 RPM.
- (3) Mixtures -- Adjust to climb fuel flow.

MAXIMUM PERFORMANCE CLIMB.

- (1) Airspeed -- 124 MPH at sea level; 122 MPH at 10,000 feet.
- (2) Power -- Full throttle and 2625 RPM.
- (3) Mixtures -- Adjust for altitude and power.

CRUISING.

- (1) Cruise Power -- 23 - 24 inches Hg. and 2100 - 2450 RPM.
- (2) Mixtures -- Lean for desired cruise fuel flow as determined from your Cessna 310 Power Computer.
- (3) Fuel Selectors - MAIN TANKS for first 60 minutes. After 60 minutes of flight, if auxiliary fuel tanks are installed, fuel selectors may then be placed in AUXILIARY position, and fuel for detent.
 - (a) If wing locker tanks are installed, fuel selectors - MAIN TANKS or, after wing locker tanks are transferred and main tank quantity is less than 30 gallons each - AUXILIARY TANKS.

NOTE

Turn auxiliary fuel pumps to LOW and mixtures to FULL RICH when switching tanks.

- (4) Trim Tabs -- Adjust.
- (5) If wing locker tanks are installed, Crossfeed -- SELECT as required to maintain fuel balance after wing locker tank fuel transfer.

OPERATING DETAILS.

Cycling the deice boots produces no adverse aerodynamic effects in any attitude within the allowable flight limitations.

Deice boots are intended to remove ice after it has accumulated rather than preventing its formation. If the rate of ice accumulation is slow, best results can be obtained by leaving the deice system OFF until 1/4 to 3/4 inch of ice has accumulated. After clearing this accumulation with one or two cycles of operation, the system should remain OFF until a significant quantity of ice has again accumulated. Rapid cycling of the system is not recommended, as this may cause the ice to grow outside the contour of the inflated boots, preventing its removal.

NOTE

Since wing and horizontal stabilizer deicer boots alone do not provide adequate protection for the entire airplane, known icing conditions should be avoided whenever possible. If icing is encountered, close attention should be given to the pitot-static system, propellers, induction systems, and other components subject to icing.

The deice system will operate satisfactorily on either or both engines. During single-engine operation, suction to the gyros will drop momentarily during the boot inflation cycle.

DEICER BOOT CARE.

Deicer boots have a special, electrically-conductive coating to bleed off static charges which cause radio interference and may perforate the boots. Fueling and other servicing operations should be done carefully, to avoid damaging this conductive coat or tearing the boots.

Keep the boots clean and free from oil and grease, which swell the rubber. Wash the boots with mild soap and water, using benzol or unleaded gasoline, if necessary, to remove stubborn grease. Do not scrub the boots and be sure to wipe off all solvent before it dries.

Small tears and abrasions can be repaired temporarily without removing the boots and the conductive coating can be renewed. Your Cessna Dealer has the proper materials and know-how to do this correctly.

DEICING SYSTEM.**OPERATING CHECKLIST.**

BEFORE ENTERING AIRPLANE:

- (1) During the exterior inspection, check the boots for tears, abrasions, and cleanliness. Have boots cleaned and any major damage repaired before takeoff.

DURING ENGINE RUNUP:

- (1) Position deicer switch to ACTUATE and check inflation and deflation cycle. The system indicator light (green in color) should light when the switch is moved to ACTUATE. The pressure indicator light (amber in color) should light when the system reaches 10 PSI. The system may be recycled as soon as the lights go OFF, or as required.

NOTE

The deicer system is manually controlled. Every time a deicing cycle is desired, the switch must be positioned to ACTUATE. The switch will instantly spring back to OFF, but a 6 second delay action in the switch will complete the deicing inflation cycle.

- (2) Check boots visually for complete deflation to the vacuum hold-down position.

NOTE

Complete inflation and deflation cycle will last approximately 30 seconds.

IN FLIGHT.

- (1) When ice has accumulated to approximately 1/2 inch thick on the leading edges, position deicer switch to ACTUATE.

AFTER LANDING.

- (1) Check boots for damage and cleanliness. Remove any accumulations of engine oil or grease.

LETDOWN.

- (1) Power -- As required.
- (2) Mixtures -- Full Rich.

BEFORE LANDING.

- (1) Fuel Selectors -- Left Engine - LEFT MAIN (feel for detent).
-- Right Engine - RIGHT MAIN (feel for detent).
- (2) Mixtures -- Full Rich.
- (3) Auxiliary Fuel Pumps -- ON.
- (4) Induction Air -- Check COLD.
- (5) Propellers -- High RPM.
- (6) Wing Flaps -- 15° below 160 MPH; 15° to 35° below 140 MPH.
- (7) Landing Gear -- Extend below 140 MPH.
- (8) Landing Gear Position Indicator Light -- Check green light on.
- (9) Approach -- 102 MPH.

LANDING.

- (1) Touchdown -- Main wheels first.
- (2) Landing Roll -- Lower nose wheel gently.
- (3) Braking -- As required.

AFTER LANDING.

- (1) Auxiliary Fuel Pumps -- OFF.
- (2) Wing Flaps -- Retract.

SECURE AIRPLANE.

- (1) Mixtures -- IDLE CUT-OFF.
- (2) Magneto Switches -- OFF, after engines stop.
- (3) All Switches -- OFF.
- (4) Brakes -- Set.
- (5) Control Lock -- Install.
- (6) Cabin Door -- Close and rotate exterior door handle clockwise to latch cabin door.

NOTE

To securely latch the cabin door from the outside, the exterior door handle must be rotated clockwise to its stop.

Notes

- (1) Battery Switch -- ON.
- (2) Propeller Anti-Ice Circuit Breaker -- Check in.
- (3) Propeller Anti-Ice Switch -- ON (up position).
- (4) Ammeter -- Check.

NOTE

Periodic fluctuation (8 to 12 Amps.) of the propeller anti-ice ammeter pointer indicates normal operation of the anti-icing elements of first one propeller and then the other.

NOTE

To check all the heating elements of both propellers and the anti-ice timer for normal operation, the system must be left ON for approximately two to two and one-half minutes.

The timer directs current to the propeller boots in cycles between boot elements and between propellers in the following cycling sequence:

- Heating Period No 1. - Outboard halves - right engine blades.
- Heating Period No 2. - Inboard halves - right engine blades.
- Heating Period No 3. - Outboard halves - left engine blades.
- Heating Period No 4. - Inboard halves - left engine blades.

Each heating period lasts for approximately one-half minute.

EMERGENCY OPERATION

Abnormal operation of the propeller anti-ice system is indicated by the circuit breaker on the circuit breaker panel opening the circuit, or by the propeller anti-ice switch tripping to the OFF position. Failure of the circuit breaker or the switch to stay reset indicates that anti-icing is impossible for the propellers.

A reading below 8 amperes on the propeller anti-ice ammeter indicates that the blades of the propeller are not being anti-iced uniformly.

WARNING

When uneven anti-icing of the propeller blades is indicated, it is imperative that the anti-ice system be turned OFF. Uneven anti-icing of the blades can result in propeller unbalance and engine failure.

NOTE

On the first operation of the oil dilution system each season, use the full dilution period, drain the oil in each engine, change the filters or clean the screens, refill with new oil and redilute as required.

If the full dilution time was used, beginning with a full oil sump (12 quarts), subsequent starts and engine warmup should be prolonged to evaporate enough of the fuel to lower the oil sump level to 12 quarts prior to takeoff. Otherwise, the sumps may overflow when the airplane is nosed-up for climb.

To avoid progressive dilution of the oil, flights of at least one hour's duration should be made between oil dilution operations.

OIL DILUTION TABLE			
	TEMPERATURE		
	0° F	-10° F	-20° F
Dilution Time	20 sec.	50 sec.	80 sec.
Fuel Added	1 qt.	2.5 qt.	4 qt.
MAXIMUM SUMP CAPACITY ——16 qt.			
MAXIMUM FOR TAKEOFF ——13 qt.			

Figure 7-2.

PROPELLER ANTI-ICE SYSTEM.

The propeller anti-ice system consists of electrically heated boots on the propeller blades. Each boot consists of two heating elements "Out-board" and "Inboard", which receive their electrical power through a anti-ice timer. To reduce power drain and maintain propeller balance, the timer directs current to the propeller boots in cycles between boot elements and between propellers.

NORMAL OPERATION.

To operate the propeller anti-ice system proceed as follows:



The following paragraphs supply a general description of some systems and equipment in the airplane. This section also covers, in somewhat greater detail, some of the items listed in Checklist form in Section I. Only those items of the Checklist requiring further explanation will be covered here.

FUEL SYSTEM

Fuel for each engine is supplied by a main tank (50 gallons useable) on each wing tip. Each engine has its own complete fuel system; two systems are interconnected only by a cross feed for emergency use. Vapor and excess fuel from the engines are returned to the main fuel tanks. Submerged electric auxiliary pumps in the main fuel tanks supply fuel for priming and starting, and for engine operation as a backup system to the engine driven pumps. Refer to Figure 2-1 for fuel system schematic.

AUXILIARY FUEL PUMP SWITCHES

The LOW position runs the pumps at low speed, providing 9 PSI pressure for purging. The ON position also runs the pumps at low speed, as long as the engine-driven pumps are functioning. With the switch positioned to ON, however, if an engine-driven pump should fail, the auxiliary pump on that side will switch to high speed automatically providing sufficient fuel for all engine operations including emergency take-off. When oil pressure (20 PSI and above) isn't available to an engine, its auxiliary fuel pump will not run.

A continuous duty tip tank transfer pump is installed in each main tip tank. The pumps assure availability of all tip tank fuel to the engine supply line during high angles of descent. Each pump is electrically protected by the respective landing light circuit breaker. When the right-hand landing light is not installed, the right-hand pump will either have a separate circuit breaker or be combined with an existing circuit breaker. During preflight inspection these pumps can be checked for operation by listening for a pulsing sound emanating from the aft tip tank fairings with the battery switch in the on position.

FUEL STRAINER AND TANK SUMP DRAINS

Refer to Servicing Procedures -- Page 5-6.

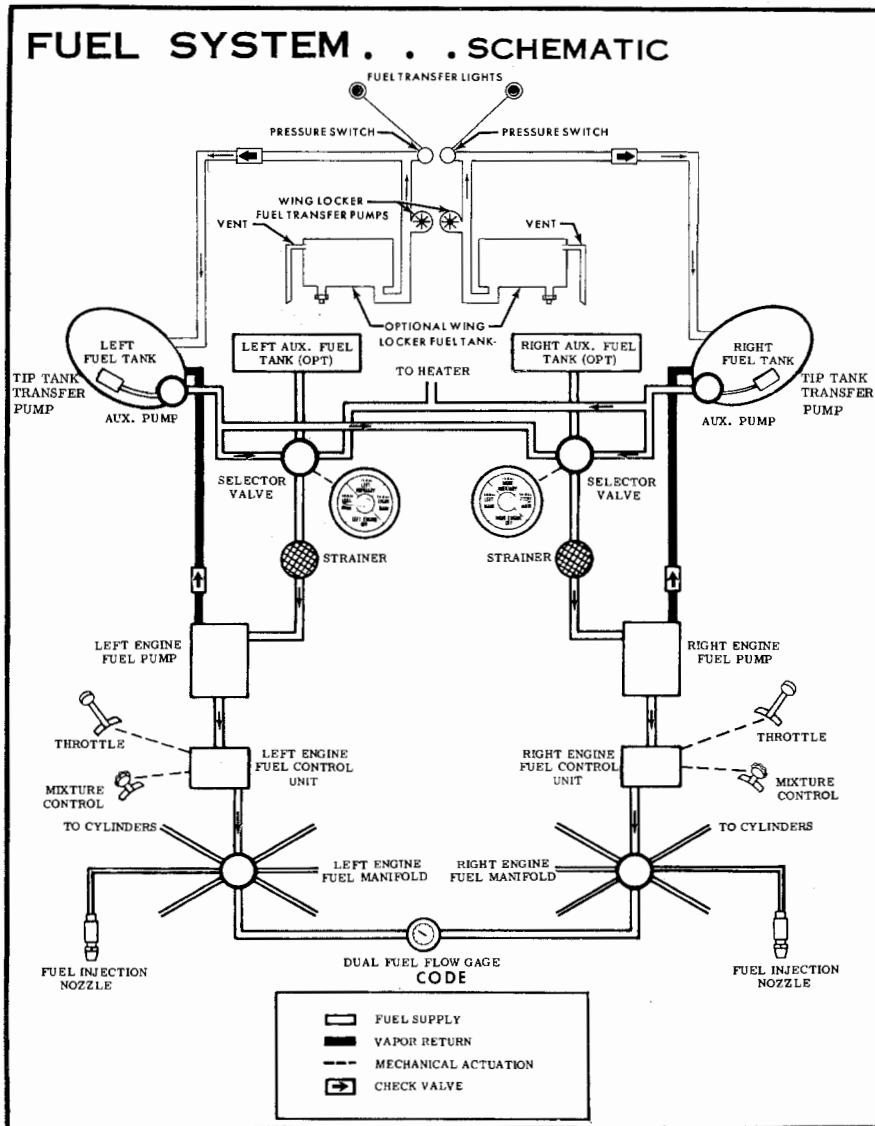

Figure 2-1.

- (1) Hose Assembly -- Select proper hose assembly for altitude.
- (2) Mask -- Connect mask and hose assembly and put mask on.
- (3) Hose Coupling -- Plug into overhead console.
- (4) Oxygen Flow Indication -- Check flow. (Ball toward mask indicates proper flow.)
- (5) Disconnect hose coupling from console when not in use.

OXYGEN SYSTEM SERVICING.

The oxygen cylinder, when fully charged, contains 48.30 cubic feet of oxygen under a pressure of 1800 PSI at 70° F. The cylinder is serviced through an external filler valve located just above the aft end of the nose wheel doors. The Servicing Requirements Table, located on the inside back cover of the manual, lists the correct type of oxygen for refilling the cylinder.

IMPORTANT

Oil, grease, or any lubricant in contact with oxygen creates a serious fire hazard and such contact must be avoided. Only a thread compound approved under MIL-T-5542 can be used safely on oxygen systems. Apply only to the first three threads of male fittings to prevent thread seizure.

The face masks used with the oxygen system are the partial-rebreathing type. The pilot's mask is a permanent type mask, while the remainder are the disposable type. A frequent user can mark and reuse his disposable type mask many times. Additional masks and hose assemblies are available from your Cessna Dealer.

COLD WEATHER EQUIPMENT.

OIL DILUTION SYSTEM.

If your airplane is equipped with an optional oil dilution system and very low temperatures are expected, dilute oil in each engine before stopping the engines. With the engines operating at 1000 RPM and the auxiliary fuel pumps in the ON position, hold the oil dilution switch to the L or R position. Refer to figure 7-2 Oil Dilution Table.

While diluting the engine oil, watch the oil pressure for any fluctuations that might indicate a filter or screen being clogged with sludge washed down by the fuel.

- (2) Oxygen Pressure Gauge -- Check for sufficient pressure for anticipated requirements of flight. (See figure 7-1.)
- (3) Check that oxygen masks and hose assemblies are available.

DURING FLIGHT:

WARNING

Permit no smoking when using oxygen. Oil, grease, soap, lipstick, lip balm, and other fatty materials constitute a serious fire hazard when in contact with oxygen. Be sure hands and clothing are oil-free before handling oxygen equipment.

OXYGEN CONSUMPTION RATE CHART

ALTITUDE RANGE-FEET	10,000 22,000	22,000 30,000
HOSE ASSEMBLY COLOR	ORANGE	RED
CONSUMPTION PSI/HR.	197	308

OXYGEN DURATION CALCULATION :

Total Oxygen Duration (Hours) = oxygen pressure indicator reading \div [oxygen consumption (PSI/HR) \times number of passengers + pilot consumption rate.]

EXAMPLE: (48.3 cu. ft. capacity) (1800 psi, oxygen pressure indicator reading)

1. Planned Flight - Pilot and 3 passengers at 20,000 feet.
2. From Chart - At 20,000 feet altitude , passenger flow rate is 197 PSI/HR. and the pilot flow rate is 308 PSI/HR.
3. Oxygen Duration = $1800 \div (3 \times 197 + 308) = 2.0$ hours.

Figure 7-1

ELECTRICAL SYSTEM

Electrical energy is supplied by a 28-volt, negative-ground, direct-current system powered by a 25-ampere engine-driven generator on each engine. Two 12-volt batteries, connected in series, are located in the left wing just outboard of the engine nacelle. An external power receptacle is installed in the left wing under the batteries. The receptacle accepts a standard power plug.

BATTERY AND GENERATOR SWITCHES

Separate battery and generator switches provide a means of checking for a malfunctioning generator circuit, and permit such a circuit to be cutoff. If a generator circuit fails or malfunctions, or when one engine is not running the switch for that generator should be turned off. Operation should be continued on the functioning generator, using only necessary electrical equipment. If both generator circuits should malfunction, equipment can be operated at short intervals and for a limited amount of time on the battery alone.

CIRCUIT BREAKERS

All of the electrical systems in the airplane are protected by "push-to-reset" type circuit breakers. When an overload occurs, the breaker pops out to indicate which circuit is overloaded.

LANDING GEAR SYSTEM

The electrically operated landing gear is fully-retractable and incorporates a steerable nosewheel. To help prevent accidental retraction, an automatic safety switch on the LEFT shock strut prevents retraction as long as the weight of the airplane is sufficient to compress the strut. The landing gear is operated by a switch, which is identified by a wheel-shaped knob. The switch positions are UP, OFF, and DOWN. To operate the gear, pull out on the switch knob and move to desired position.

LANDING GEAR POSITION LIGHTS

Two landing gear position lights are mounted one above the other below the landing gear switch. The lights are push-to-test type with dimming shutters. Brightness can be controlled by rotating the shutters. When illuminated the red light indicates the gear is fully retracted, and the green light illuminates when the landing gear is fully extended and locked. When neither light is on, the landing gear is in an intermediate position.

SECTION II

LANDING GEAR WARNING HORN.

The landing gear warning horn is controlled by the throttles, and will sound an intermittent note if either throttle is retarded below approximately 12 inches Hg. manifold pressure with the gear up. The warning horn is also connected to the UP position of the landing gear switch, and will sound if the switch is placed in the UP position while the airplane is on the ground.

LANDING GEAR HANDCRANK.

A handcrank for manually lowering the landing gear is located just below the right front edge of the pilot's seat.

NOTE

The handcrank handle must be stowed in its clip before the landing gear will operate electrically. When the handle is placed in operating position, it disengages the landing gear motor from the actuator gear.

The procedure for manually lowering the landing gear is given in Section III.

HEATER SYSTEM.

HEATER OPERATION FOR HEATING AND DEFROSTING.

- (1) Battery Switch -- ON.
- (2) Cabin Air Knobs -- OPEN.
- (3) Defrost Knob -- Adjust as desired (if defrosting is desired).
- (4) Temperature Control Knob -- MAX.
- (5) Cabin Heat Switch -- HEAT.
- (6) Temperature Control and Heat Registers -- As desired.

NOTE

If warm air is not felt coming out of the registers within one minute, return cabin heat switch to OFF, check circuit breaker and try another start. If heater still does not start, no further starting attempt should be made.



SECTION VII OPTIONAL SYSTEMS

This section contains a description, operating procedures, and performance data (when applicable) for some of the optional equipment which may be installed in your Cessna Model 310. Contact your Cessna Dealer for a complete list of available Cessna Model 310 Optional Equipment.

AUXILIARY FUEL SYSTEM.

Auxiliary tanks (15 gal. usable each wing) are installed in each wing just outboard of each engine nacelle and feed directly to the fuel selector valves. Fuel vapor and excess fuel from the engines are returned to the main fuel tanks.

When the selector valve handles are in the "AUXILIARY" position, the left auxiliary tank feeds the left engine and the right auxiliary tank feeds the right engine. If the auxiliary tanks are to be used, select fuel from the main tanks for 60 minutes prior to switching to auxiliary tanks. This is necessary to provide space in the main tanks for vapor and fuel returned from the engine-driven fuel pumps when operating on auxiliary tanks.

OXYGEN SYSTEM.

The oxygen system is designed to provide adequate oxygen flow rates for altitudes up to 30,000 feet. The system is calibrated for two different altitude ranges, which are: 10,000 to 22,000 feet and 22,000 to 30,000 feet. Selection of the desired altitude range is accomplished by appropriate selection of color coded hose assemblies. See figure 7-1 for oxygen consumption.

NOTE

The pilot should always select the red hose assembly.

OXYGEN SYSTEM OPERATION.

BEFORE FLIGHT:

- (1) Oxygen Knob -- PULL ON.

CRUISE PERFORMANCE WITH NORMAL LEAN MIXTURE AT 15,000 FT.								
RPM	MP	% BHP	TAS	Total Gals./Hr.	Endurance 100 Gals.	Range 100 Gals.	Endurance 130 Gals.	Range 130 Gals.
2450	16	53	199	20.2	5.0	985	6.5	1280
	15	48	187	18.7	5.4	1000	7.0	1300
	14	44	173	17.3	5.8	1000	7.5	1300
2300	16	48	187	18.7	5.4	1000	7.0	1300
	15	44	171	17.3	5.8	990	7.5	1285
2200	16	44	173	17.3	5.8	1000	7.5	1300

CRUISE PERFORMANCE IS BASED ON STANDARD CONDITIONS, ZERO WIND, NORMAL LEAN MIXTURE, 100 AND 130 GALLONS OF FUEL (NO RESERVE), AND 5100 POUNDS GROSS WEIGHT.

CRUISE PERFORMANCE WITH NORMAL LEAN MIXTURE AT 20,000 FT.								
RPM	MP	% BHP	TAS	Total Gals./Hr.	Endurance 100 Gals.	Range 100 Gals.	Endurance 130 Gals.	Range 130 Gals.
2450	13.5	46	179	18.0	5.6	995	7.22	1290

CRUISE PERFORMANCE IS BASED ON STANDARD CONDITIONS, ZERO WIND, NORMAL LEAN MIXTURE, 100 AND 130 GALLONS OF FUEL (NO RESERVE), AND 5100 POUNDS GROSS WEIGHT.

Figure 6-9. (Sheet 3 of 3)

HEATER USED FOR VENTILATION.

- (1) Battery Switch -- ON.
- (2) Cabin Air Knobs -- OPEN.
- (3) Cabin Heat Switch -- FAN.
- (4) Heat Registers -- As desired.

OVERHEAT WARNING LIGHT.

An amber overheat warning light is provided and is labeled HEATER-OVERHEAT, T & B TEST. When illuminated, the light indicates that the heater overheat switch has been actuated and indicates the temperature of the air in the heater exceeds 325° F. Once the heater overheat switch has been actuated, the heater turns off and cannot be restarted until the overheat switch is reset. Prior to having the overheat switch reset, the heater should be inspected thoroughly to determine the reason for the malfunction.

STATIC- PRESSURE ALTERNATE-SOURCE VALVE.

A static-pressure alternate-source valve, installed in the static system, directly below the parking brake handle, supplies an alternate static source should the external source malfunction. This valve also permits draining condensate from the static lines. When open, this valve vents to the static pressure in the cabin and since this is relatively low, the airspeed indicator and the altimeter will show slightly higher readings than normal. Therefore, the alternate static source should be used primarily as a drain valve to restore the original system.

If the alternate static source must be used for instrument operation, compensation should be made in the indicated airspeeds and altitudes. In landing with the alternate source valve open and the pilot's storm window closed, fly at an indicated airspeed 10 MPH faster and an altitude 30 feet higher than normal. With the static source valve open and the pilot's storm window open, make these allowances, 26 MPH and 160 feet.

STARTING ENGINES.

Although either engine may be started first and the procedure is identical for both, the left engine is normally started first. The cable from

the battery to this engine is much shorter, which permits more electrical power to be delivered to the starter. If batteries are low, the left engine should start more readily.

When using an external power source, it is recommended to start the airplane with the battery switch OFF.

The continuous flow fuel injection system will start spraying fuel in the engine intake ports as soon as the primer switch is pressed on and the throttle and mixture controls are opened. To avoid flooding, be sure you are ready to crank the engine as soon as a steady fuel flow is obtained.

In hot weather with a hot engine, a fluctuating fuel flow slightly lower than normal may be obtained. This is an indication of vaporized fuel and the starter should not be energized until a steady fuel flow indication is obtained.

NOTE

Caution should be exercised to prevent overpriming the engine in hot weather.

Engine mis-starts characterized by weak, intermittent explosions followed by puffs of black smoke from the exhaust are the result of flooding or overpriming. This situation is more apt to develop in hot weather, or when the engines are hot. If it occurs, repeat the starting procedure with the throttle open approximately 1/2, the mixture in idle cut-off and the primer switch off. As the engine fires, move the mixture control to full rich and close the throttle to idle.

If an engine is underprimed, as may occur in cold weather with a cold engine, repeat the starting procedure after holding the primer switch on for 10 to 15 seconds until the engine fires.

If cranking longer than 30 seconds is required, allow starter motor to cool for five minutes before cranking again, since excessive heat may damage the armature windings.

TAXIING.

A steerable nosewheel interconnected with the rudder system provides positive control up to 15° left or right, and free turning from 15° to 55°

CRUISE PERFORMANCE WITH NORMAL LEAN MIXTURE AT 7,500 FT.								
RPM	MP	%BHP	TAS	Total Gals./Hr.	Endurance 100 Gals.	Range 100 Gals.	Endurance 130 Gals.	Range 130 Gals.
2450	22	71	216	26.5	3.8	815	4.9	1060
	21	67	210	25.0	4.0	840	5.2	1090
	20	63	204	23.5	4.3	870	5.5	1130
	19	58	198	22.0	4.5	900	5.9	1170
2300	22	64	206	24.0	4.2	860	5.4	1115
	21	60	201	22.7	4.4	885	5.7	1150
	20	56	194	21.2	4.7	915	6.0	1190
	19	53	188	20.2	4.9	930	6.4	1200
2200	22	58	198	22.0	4.5	900	5.9	1170
	21	55	193	21.0	4.8	920	6.2	1195
	20	52	187	19.8	5.1	945	6.6	1225
	19	48	179	18.7	5.4	955	6.9	1245
2100	21	50	183	19.2	5.2	955	6.8	1240
	20	47	177	18.3	5.5	965	7.1	1255
	19	44	169	16.8	5.9	1000	7.7	1315
	18	40	159	16.2	6.2	980	8.1	1275
	17	37	144	15.3	6.5	940	8.5	1225

CRUISE PERFORMANCE IS BASED ON STANDARD CONDITIONS, ZERO WIND, NORMAL LEAN MIXTURE, 100 AND 130 GALLONS OF FUEL (NO RESERVE), AND 5100 POUNDS GROSS WEIGHT.

CRUISE PERFORMANCE WITH NORMAL LEAN MIXTURE AT 10,000 FT.								
RPM	MP	%BHP	TAS	Total Gals./Hr.	Endurance 100 Gals.	Range 100 Gals.	Endurance 130 Gals.	Range 130 Gals.
2450	20	65	212	24.4	4.1	870	5.3	1130
	19	61	206	22.8	4.4	905	5.7	1175
	18	57	199	21.5	4.7	925	6.1	1205
	17	53	192	20.0	5.0	960	6.5	1250
2300	20	59	203	22.0	4.5	925	5.9	1200
	19	55	196	20.8	4.8	940	6.2	1225
	18	51	188	19.7	5.1	955	6.6	1240
	17	48	181	18.5	5.4	978	7.0	1270
2200	20	54	193	20.5	4.9	940	6.3	1225
	19	50	187	19.3	5.2	970	6.7	1260
	18	47	179	18.2	5.5	985	7.1	1280
	17	44	171	17.3	5.8	990	7.5	1285
2100	20	49	183	18.8	5.3	975	6.9	1265
	19	46	176	17.8	5.6	990	7.3	1285
	18	43	167	16.8	5.9	995	7.8	1290
	17	40	153	16.0	6.3	955	8.1	1245

CRUISE PERFORMANCE IS BASED ON STANDARD CONDITIONS, ZERO WIND, NORMAL LEAN MIXTURE, 100 AND 130 GALLONS OF FUEL (NO RESERVE), AND 5100 POUNDS GROSS WEIGHT.

Figure 6-9. (Sheet 2 of 3)

CRUISE PERFORMANCE WITH NORMAL LEAN MIXTURE AT 2,500 FT.								
RPM	MP	% BHP	TAS	Total Gals./Hr.	Endurance 100 Gals.	Range 100 Gals.	Endurance 130 Gals.	Range 130 Gals.
2450	24	74	211	28.0	3.6	755	4.6	980
	23	70	205	26.3	3.8	780	4.9	1015
	22	66	200	24.5	4.1	815	5.3	1060
	21	62	195	23.2	4.3	840	5.6	1095
2300	24	68	203	25.5	3.9	795	5.1	1035
	23	64	197	23.8	4.2	825	5.5	1075
	22	60	191	22.5	4.4	850	5.8	1105
	21	56	186	21.2	4.7	880	6.1	1140
2200	23	58	189	21.8	4.6	865	6.0	1125
	22	55	184	20.7	4.8	890	6.3	1155
	21	50	177	19.3	5.2	920	6.7	1190
	20	47	172	18.3	5.5	940	7.1	1220
2100	22	49	174	18.8	5.3	925	6.9	1200
	21	46	169	17.8	5.6	950	7.3	1230
	20	43	161	16.8	5.9	960	7.7	1245
	19	40	155	16.2	6.2	955	8.0	1245
	18	37	144	15.0	6.7	960	8.7	1250

CRUISE PERFORMANCE IS BASED ON STANDARD CONDITIONS, ZERO WIND, NORMAL LEAN MIXTURE, 100 AND 130 GALLONS OF FUEL (NO RESERVE), AND 5100 POUNDS GROSS WEIGHT.

CRUISE PERFORMANCE WITH NORMAL LEAN MIXTURE AT 5,000 FT.								
RPM	MP	% BHP	TAS	Total Gals./Hr.	Endurance 100 Gals.	Range 100 Gals.	Endurance 130 Gals.	Range 130 Gals.
2450	24	77	219	29.0	3.4	755	4.5	980
	23	73	213	27.3	3.7	780	4.8	1015
	22	68	209	25.7	3.9	815	5.1	1055
	21	64	203	24.2	4.1	840	5.4	1090
2300	24	70	209	26.2	3.8	800	5.0	1035
	23	66	204	24.7	4.0	825	5.3	1075
	22	62	200	23.2	4.3	860	5.6	1120
	21	58	193	21.8	4.6	885	6.0	1150
2200	23	61	197	22.7	4.4	870	5.7	1130
	22	57	191	21.3	4.7	895	6.1	1165
	21	53	185	20.2	5.0	915	6.5	1190
	20	50	179	19.2	5.2	930	6.8	1210
2100	22	51	182	19.7	5.1	925	6.6	1200
	21	48	175	18.5	5.4	945	7.1	1230
	20	45	169	17.7	5.7	955	7.3	1240
	19	42	161	16.5	6.1	975	7.9	1270
	18	39	151	15.7	6.4	960	8.3	1250

CRUISE PERFORMANCE IS BASED ON STANDARD CONDITIONS, ZERO WIND, NORMAL LEAN MIXTURE, 100 AND 130 GALLONS OF FUEL (NO RESERVE), AND 5100 POUNDS GROSS WEIGHT.

Figure 6-9. (Sheet 1 of 3)

for sharp turns during taxiing. Steering may be aided thru use of differential power and differential braking on the main wheels. These aids are listed in the preferred order of use.

BEFORE TAKEOFF (Use The Pilot's Checklist).

Full throttle checks on the ground are not recommended unless there is good reason to suspect that the engines are not turning-up properly. Do not run-up the engines over loose gravel or cinders because of possible stone damage or abrasion to the propeller tips.

If the ignition system check produces an engine speed drop in excess of 125 RPM or if the drop in RPM between left and right magneto differs by more than 50 RPM, continue warm-up a minute or two longer, before re-checking system. If there is doubt concerning operation of the ignition system, checks at higher engine speed will usually confirm if a deficiency exists.

TAKEOFF.

Observe full-power engine operation early in the takeoff run. Signs of rough engine operation, unequal power between engines, or sluggish engine acceleration are good cause for discontinuing the takeoff.

For maximum engine power, the mixture should be adjusted during the initial acceleration for smooth engine operation at the field elevation. The engine acceleration is increased significantly with fuel leaning above 3000 feet and this procedure always should be employed for field elevations greater than 5000 feet above sea level.

Full throttle operation is recommended on takeoff since it is important that a speed well above minimum single-engine control speed (87 MPH) be reached as rapidly as possible.

After takeoff it is important to maintain the recommended safe single-engine speed (102 MPH). After obstruction height is reached, the gear retracted, power may be reduced and climb speeds may be established as described in Section I.

On long runways, the landing gear should be retracted at the point over the runway where a wheels-down forced landing on that runway would be-

come impractical. However, on short runways, it is preferable to retract the landing gear after minimum control speed (87 MPH) is obtained.

Performance data for both normal and obstacle clearance takeoff are presented in Section VI.

CLIMB.

To save time and fuel for the over-all trip, it is recommended that the normal cruising climb be conducted at 130 to 160 MPH using approximately 75% power (24 inches Hg. manifold pressure, 2450 RPM).

The mixture should be leaned in this type of climb to give the desired fuel flow in the climb dial range which is approximately best power mixture.

If it is necessary to climb rapidly to clear mountains or reach favorable winds at high altitudes, the best rate-of-climb speed should be used with maximum power. This speed varies from 124 MPH at sea level to 122 MPH at 10,000 feet. During maximum performance climbs, the mixture should be leaned to the appropriate altitude markings on the fuel flow gage.

If an obstruction ahead requires a steep climb angle, the airplane should be flown at the best angle-of-climb speed with flaps up and maximum power. This speed varies from 95 MPH at sea level to 111 MPH at 15,000 feet.

CRUISE.

Tabulated cruising information for normal cruising power and altitudes is presented in Section VI.

Normal cruising requires between 60% and 70% power. The manifold pressure and RPM settings required to obtain these powers at various altitudes and outside air temperature can be determined with your Cessna Model 310 Power Computer. The maximum cruising power of approximately 75% (24 inches Hg. manifold pressure, 2450 RPM) may be used if desired.

Various percent powers can be obtained with a number of combinations of manifold pressures, engine speeds, altitudes, and outside air tempera-

MAXIMUM PERFORMANCE TAKEOFF 15° FLAPS											
Gross Weight Pounds	IAS at Takeoff MPH	IAS at Obstacle MPH	Head Wind MPH	DENSITY ALTITUDE							
				SEA LEVEL		2500 FT.		5000 FT.		7500 FT.	
				Ground Run	Total Distance over 50 Ft Obstacle	Ground Run	Total Distance over 50 Ft Obstacle	Ground Run	Total Distance over 50 Ft Obstacle	Ground Run	Total Distance over 50 Ft Obstacle
5100	87	87	0 15 30	1385 1077 919	1640 1290 1107	1630 1280 1100	1929 1531 1323	1915 1511 1310	2265 1807 1574	2340 1870 1635	2766 2233 1960

Figure 6-7.

LANDING PERFORMANCE									
Gross Weight Pounds	IAS at Obstacle MPH	SEA LEVEL 59° F		2500 FT. 50° F		5000 FT. 41° F		7500 FT. 32° F	
		Ground Run	Total Distance Over 50 Foot Obstacle	Ground Run	Total Distance Over 50 Foot Obstacle	Ground Run	Total Distance Over 50 Foot Obstacle	Ground Run	Total Distance Over 50 Foot Obstacle
4300	85	660	1240	710	1290	766	1346	827	1407
4700	91	801	1381	862	1442	929	1509	1004	1584
5100	102	960	1540	1034	1614	1114	1640	1203	1783

NOTE: WING FLAPS 35°, POWER OFF, HARD SURFACE RUNWAY, ZERO WIND, MAXIMUM BRAKING EFFORT. REDUCE LANDING DISTANCE 10% FOR EACH 10 MPH HEADWIND.

Figure 6-8.

TWIN ENGINE CLIMB DATA															
Gross Weight Pounds	At Sea Level and 59° F			At 5000 Ft and 41° F			At 10,000 Ft and 23° F			At 15,000 Ft and 5° F			At 20,000 Ft and -12° F		
	Best Climb IAS mph	Rate of Climb Ft/Min	Gal. of Fuel Used	Best Climb IAS mph	Rate of Climb Ft/Min	From S. L. Fuel Used	Best Climb IAS mph	Rate of Climb Ft/Min	From S. L. Fuel Used	Best Climb IAS mph	Rate of Climb Ft/Min	From S. L. Fuel Used	Best Climb IAS mph	Rate of Climb Ft/Min	From S. L. Fuel Used
4300	111	2070	4.0	110	1850	5.8	109	1240	7.7	107	825	10.0	106	410	13.4
4700	118	1795	4.0	117	1405	6.1	116	1020	8.4	115	640	11.3	114	255	16.3
5100	124	1590	4.0	123	1220	6.4	122	855	9.1	121	490	12.7	120	120	20.4

NOTE: FULL THROTTLE, 2825 RPM, MIXTURE AT RECOMMENDED LEANING SCHEDULE, FLAPS AND GEAR UP. FUEL USED INCLUDES WARM-UP AND TAKEOFF ALLOWANCE.

SINGLE ENGINE CLIMB DATA										
Gross Weight Pounds	At Sea Level and 59° F		At 2500 Ft and 50° F		At 5000 Ft and 41° F		At 7500 Ft and 32° F		At 10,000 Ft and 23° F	
	Best Climb IAS mph	Rate of Climb Ft/Min	Best Climb IAS mph	Rate of Climb Ft/Min	Best Climb IAS mph	Rate of Climb Ft/Min	Best Climb IAS mph	Rate of Climb Ft/Min	Best Climb IAS mph	Rate of Climb Ft/Min
4300	114	580	111	440	110	325	108	210	107	80
4700	115	460	114	345	112	235	111	125	109	20
5100	118	360	116	255	115	155	114	50	113	-55

NOTE: FULL THROTTLE, 2825 RPM AND MIXTURE AT RECOMMENDED LEANING SCHEDULE. DECREASE RATE OF CLIMB 10 FT/MIN FOR EACH 10° F ABOVE STANDARD TEMPERATURE FOR PARTICULAR ALTITUDE.

tures. However, at full throttle and constant engine speed, a specific power can be obtained at only one altitude for each given air temperature.

To achieve the level flight performance shown in the cruising charts in Section VI, lean the mixtures to give the fuel flows shown. This will yield airspeeds slightly below (approximately one to two MPH) those available at best power mixture.

Should maximum speed be desirable, the mixture should be adjusted to approximately one gph higher than that indicated by the range charts on the Cessna Model 310 Power Computer. This will yield approximately best power mixture with a resulting airspeed of one to two MPH greater and a fuel flow approximately one gallon per hour greater than those listed in Section VI.

For a given throttle setting, select the lowest engine speed in the green arc range that will give smooth engine operation without evidence of laboring.

For best propeller synchronization, the final adjustment of the propeller pitch levers should be made in a DECREASE RPM direction.

The induction air system employed on these engines is considered to be non-icing. However, induction air heat is incorporated to assure satisfactory operation in the unlikely event that unusual atmospheric conditions should cause induction system icing. The induction air handles should be left in the full COLD position for all normal operations. Should induction system icing be encountered, the induction air handles should be pulled to the full heat position. If this condition occurs the engine mixture control should be leaned for smooth engine operation.

STALL.

The stall characteristics of this airplane are conventional and aural warnings are provided by the stall warning horn between 5 and 10 MPH above the stall in all configurations. The stall is also preceded by a mild aerodynamic buffet which increases in intensity as the stall is approached. The power-on stall occurs at a very steep angle either with or without flaps, and it is difficult to inadvertently stall the airplane during normal maneuvering.

Power-off stall speeds at maximum gross weight are presented in Figure 6-2 as both indicated and calibrated airspeeds.

Figure 6-6.

SPINS.

Intentional spins are not permitted in this airplane. Should a spin occur, however, the following recovery procedure should be employed:

- (1) Cut power on both engines.
- (2) Apply full rudder opposing the direction of rotation.
- (3) Approximately 1/2 turn after applying rudder, push control wheel forward briskly.
- (4) To expedite recovery, add power to the engine toward the inside of the direction of turn.
- (5) Pull out of dive with smooth, steady control pressure.

COLD WEATHER OPERATION.

Whenever possible, external preheat should be utilized in cold weather. The use of preheat materially reduces the severity of conditions imposed on both the engines and electrical systems. It is the preferred or best method of starting engines in extremely cold weather. Preheat will thaw the oil trapped in the oil coolers and optional oil filters which will probably be congealed prior to starting in very cold weather.

If preheat is not available, external power should be used for starting because of the higher cranking power required, and the decreased battery output at low temperatures. The starting procedure is normal, however, if the engines do not start immediately it may be necessary to position the primer switch to LEFT or RIGHT for 10 to 15 seconds.

After a suitable warm-up period (2 to 5 minutes at 1000 RPM if preheat is not used) accelerate the engines several times to a higher RPM. The propellers should be operated through several complete cycles to warm the governors and propeller hubs. If the engines accelerate smoothly, the oil pressure remains normal and steady, the airplane is ready for take-off.

During cruise the propellers should be exercised at half-hour intervals to flush the cold oil from the governors and propeller hubs. Electrical equipment should be managed to assure adequate generator charging throughout the flight, since cold weather adversely affects battery capacity.

During letdown, watch engine temperatures closely and carry sufficient power to maintain them above operating minimums.

SINGLE ENGINE TAKEOFF DISTANCE

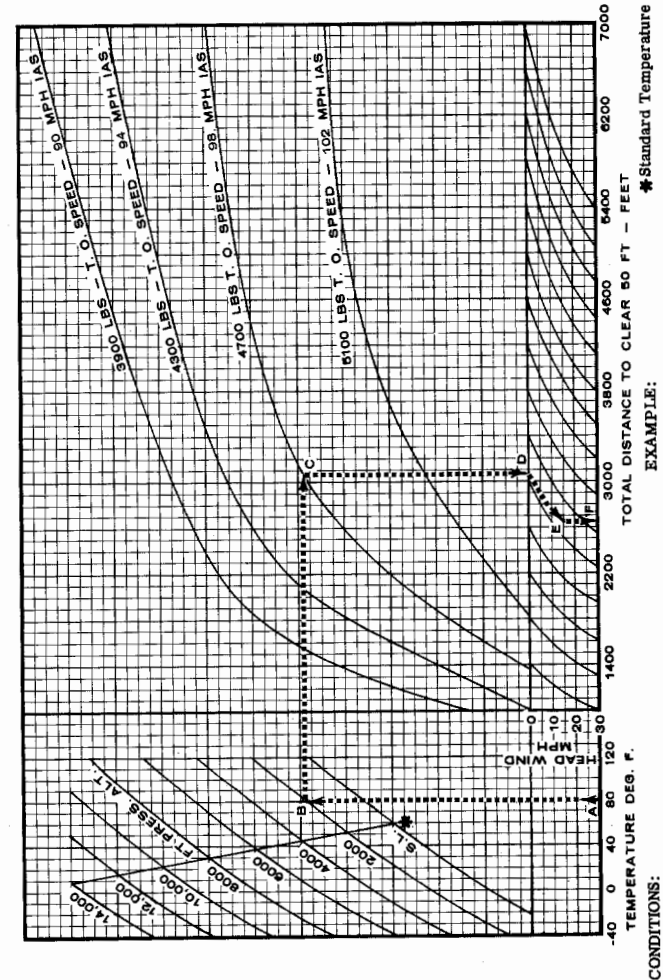

CONDITIONS:

1. Level Hard Surface Runway.
2. Wing Flaps UP.
3. Full Throttle and 2625 RPM Before Releasing Brakes.
4. Mixture at Recommended Fuel Flow.
5. Engine Failure at Takeoff Speed.
6. Propeller Feathered and Gear Retracted During Climb.
7. Maintain Speed to 50 Feet.

EXAMPLE:

- A. Temperature - 80° F.
- B. Pressure Altitude - 2000 Ft.
- C. Gross Weight - 4700 Lbs.
- D. Total Distance to Clear 50 Ft. (No Wind) - 3080 Ft.
- E. Headwind - 15 MPH.
- F. Total Distance to Clear 50 Ft. (15 MPH Headwind) - 2650 Ft.

Figure 6-5.

ACCELERATE STOP DISTANCE

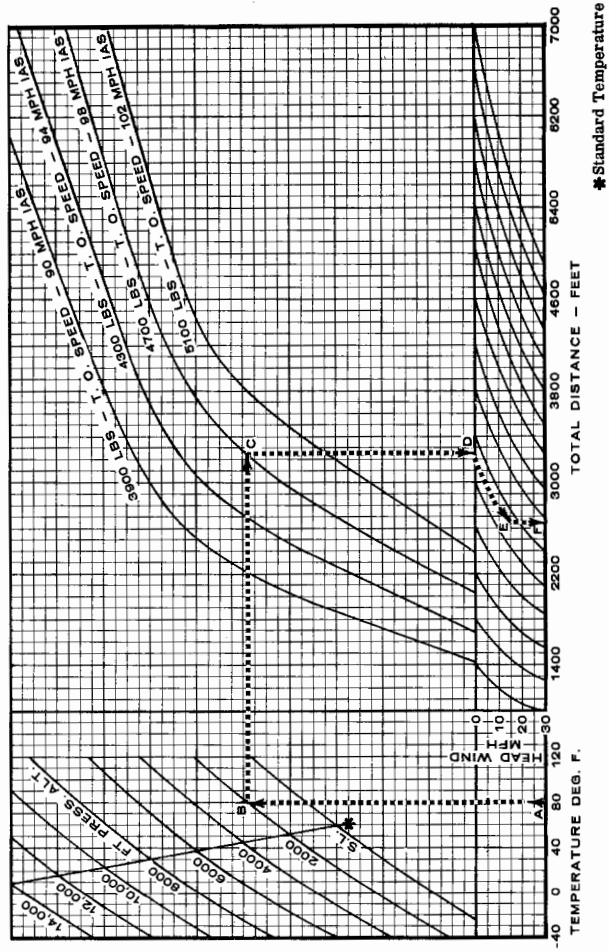

CONDITIONS:

1. Level Hard Surface Runway.
2. Wing Flaps UP.
3. Full Throttle and 2625 RPM Before Releasing Brakes.
4. Mixture at Recommended Fuel Flow.
5. Engine Failure at Takeoff Speed.
6. Heavy Braking After Engine Failure.

EXAMPLE:

- A. Temperature - 80° F.
- B. Pressure Altitude - 2000 Ft.
- C. Gross Weight - 4700 Lbs.
- D. Total Distance to Stop (No Wind) - 3250 Ft.
- E. Headwind - 15 MPH
- F. Total Distance to Stop (15 MPH Headwind) - 2650 Ft.

The pitot and stall warning heater switch should be turned ON at least 5 minutes before entering a potential icing condition so that these units will be warm enough to prevent formation of ice. Preventing ice is preferable to attempting its removal once it has formed.

Refer to Section VII for Optional Cold Weather Equipment.

Figure 6-4.

Notes

NORMAL TAKEOFF DISTANCE

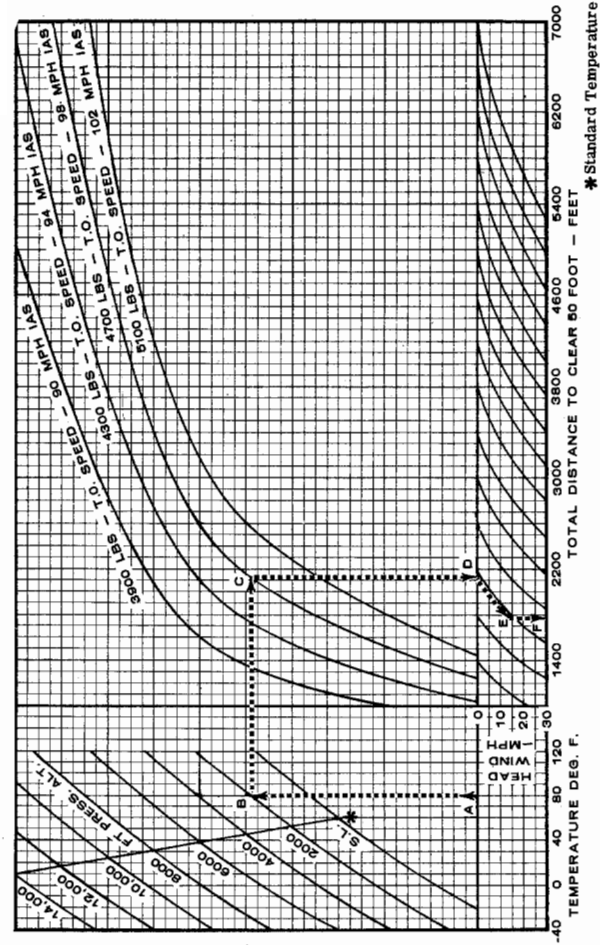

CONDITIONS:

1. Level Hard Surface Runway.
2. Wing Flaps UP.
3. Full Throttle and 2625 RPM Before Releasing Brakes.
4. Mixture at Recommended Fuel Flow.
5. Maintain Speed to 50 Feet.

EXAMPLE:

- A. Temperature - 80°F.
- B. Pressure Altitude - 2000 Ft.
- C. Gross Weight - 4700 Lbs.
- D. Total Distance to Clear 50 Ft. (No Wind) - 2125 Ft.
- E. Headwind - 15 MPH.
- F. Total Distance to Clear 50 Ft. (15 MPH Headwind) - 1775 Ft.

Figure 6-3.

AIRSPEED CORRECTION TABLE					
Flaps 0°		Flaps 15°*		Flaps 35°**	
IAS, MPH	CAS, MPH	IAS, MPH	CAS, MPH	IAS, MPH	CAS, MPH
80	79	70	77	70	73
100	99	80	83	80	80
120	118	90	91	90	88
140	138	100	98	100	97
160	158	110	107	110	106
180	178	120	117	120	116
200	198	130	127	130	127
220	217	140	138	140	138
240	237	150	149		
		160	160		

* Maximum Flap Speed 160 MPH (15°) ** Maximum Flap Speed 140 MPH (35°)

Figure 6-1.

STALL SPEED CHART								
MPH								
5100 POUNDS GROSS WEIGHT, IDLE POWER								
CONFIGURATION	ANGLE OF BANK							
	0°		20°		40°		60°	
	IAS	CAS	IAS	CAS	IAS	CAS	IAS	CAS
Gear and Flaps Up	86	85	89	88	98	97	122	120
Gear Down and Flaps 15°	79	83	82	85	95	94	121	117
Gear Down and Flaps 35°	78	79	81	81	92	90	115	111

Figure 6-2.



SECTION III EMERGENCY PROCEDURES

ENGINE-OUT PROCEDURES.

ENGINE-OUT ON TAKEOFF.

(With Sufficient Runway Remaining).

- (1) Cut power and decelerate to a stop.

NOTE

The airplane can be accelerated from a standing start to 102 MPH on the ground, then decelerated to a stop with heavy braking within 3046 feet of the starting point of the takeoff run at sea level, and within 3863 feet of the starting point at 5000 feet altitude (zero wind, hard surface runway, standard conditions, full gross weight).

ENGINE-OUT AFTER TAKEOFF—ABOVE 102 MPH.

(Without Sufficient Runway Ahead).

- (1) Throttles -- Full Forward.
- (2) Propellers -- High RPM.
- (3) Landing Gear -- UP.
- (4) Determine Inoperative Engine (idle engine same side as idle foot).
- (5) Propeller -- FEATHER (inoperative engine).
- (6) Climb Out at 102 MPH.
- (7) Accelerate to 118 MPH after Obstacle is Cleared.
- (8) Wing Flaps -- UP (if extended) in small increments.
- (9) Secure Inoperative Engine as Follows:
 - (a) Auxiliary Fuel Pump -- OFF.
 - (b) Mixture -- IDLE CUT-OFF.
 - (c) Magneto Switches -- OFF.
 - (d) Generator Switch -- OFF.
 - (e) Fuel Selector Valve -- OFF.

**SUPPLEMENTARY INFORMATION CONCERNING
ENGINE-OUT DURING TAKEOFF.**

The most critical time for an engine-out condition in a twin-engine airplane is during a two or three second period late in the takeoff run while the airplane is accelerating to a safe engine-out speed. A detailed knowledge of recommended single-engine airspeeds in the table below is essential for safe operation of this airplane.

These speeds should be memorized for instant recollection in an emergency, and it is worthwhile to review them mentally, prior to every takeoff. The following paragraphs present a detailed discussion of the problems associated with engine failures during takeoff.

SINGLE-ENGINE AIRSPEED NOMENCLATURE	IAS—MPH
1. Minimum control speed	87
2. Recommended safe single-engine speed	102
3. Best angle-of-climb speed	107
4. Best rate-of-climb speed (flaps up)	118

MINIMUM CONTROL SPEED. The twin-engine airplane must reach the minimum control speed (87 MPH) before full control deflections can counteract the adverse rolling and yawing tendencies associated with one engine inoperative and full power operation on the other engine.

RECOMMENDED SAFE SINGLE-ENGINE SPEED. Although the airplane is controllable at the minimum control speed, the airplane performance is so far below optimum that continued flight near the ground is improbable. A more suitable recommended safe single-engine speed is 102 MPH since at this speed altitude can be maintained more easily while the landing gear is being retracted and the propeller is being feathered.

BEST ANGLE-OF-CLIMB SPEED. The best angle-of-climb speed for single-engine operation becomes important when there are obstacles ahead on takeoff, because once the best single-engine angle-of-climb speed is reached, altitude becomes more important than airspeed until the obstacle is cleared. The best single-engine angle-of-climb speed is approximately 107 MPH with flaps up. For convenience, a speed of 102 MPH may be used for any flap setting between 0 - 15°.

BEST RATE-OF-CLIMB SPEED (FLAPS UP). The best rate-of-climb speed for single-engine operation becomes important when there are no obstacles ahead on takeoff, or when it is difficult to maintain or gain altitude in single-engine emergencies. The best single-engine rate-of-climb speed is 118 MPH with flaps up, at sea level. The variation of flaps-up

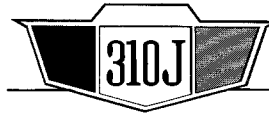
**SECTION VI
OPERATIONAL DATA**

The operational data charts on the following pages are presented for two purposes; first, so that you may know what to expect from your airplane under various conditions; and second, to enable you to plan your flights in detail and with reasonable accuracy.

A power setting selected from the range charts usually will be more efficient than a random setting, since it will permit accurate fuel flow settings and your fuel consumption can be estimated closely. You will find that using the charts and your Cessna 310 Power Computer will pay dividends in over-all efficiency.

The data in the charts has been compiled from actual flight tests with the airplane and engines in good condition, and using average piloting techniques. Note also that the range charts make no allowances for wind, navigational errors, warm-up, take-off, climb, etc. You must estimate these variables for yourself and make allowances accordingly.

**DETERMINATION OF RANGE AND ENDURANCE WITH WING LOCKER
FUEL SYSTEM**

Increases in range and endurance with wing locker tanks can be determined from the cruise performance charts, see Figure 6-9, by using 4/3 of the same increment of increase that is gained from the auxiliary tanks over the standard tanks. If only one wing locker tank is installed, use 2/3 of the increment of increase that is gained from the auxiliary tanks over the standard tanks.

- (3) Magneto Switches - OFF.
- (4) Propellers - ROTATE CLOCKWISE. Manually rotate propellers five revolutions, standing clear of arc of propeller blades.

Keep fuel tanks full to minimize condensation in the fuel tanks. Maintain battery at full charge to prevent electrolyte from freezing in cold weather. If the aircraft is stored outside, tie-down aircraft in anticipation of high winds. Secure aircraft as follows:

- (1) Secure rudder with the optional rudder gust lock or with a control surface lock over the fin and rudder. If a lock is not available, caster the nose wheel to the full left or right position.
- (2) Install control column lock in pilot's control column, if available. If column lock is not available, tie the pilot's control wheel full aft with a seat belt.
- (3) Tie ropes or chains to the wing tie-down fittings located on the underside of each wing. Secure the opposite ends of the ropes or chains to ground anchors. Chock the main landing gear tires; do not set the parking brake if a long period of inactivity is anticipated as brake seizing can result.
- (4) Secure a rope (no chains or cables) to the upper nose gear trunion and secure opposite end of rope to a ground anchor. Chock the nose landing gear tire.
- (5) Secure the middle of a rope to the tail tie-down fitting. Pull each end of rope at a 45-degree angle and secure to ground anchors at each side of the tail.
- (6) After 30 days, the aircraft should be flown for 30 minutes or run engines on the ground until oil temperatures reach operating temperatures.

NOTE

Excessive ground operation is to be avoided so that maximum cylinder head temperatures are not exceeded.

best rate-of-climb speed with altitude is shown in Section VI. For best climb performance, the wings should be banked 5° toward the operative engine.

Upon engine failure after reaching 102 MPH on takeoff, the twin-engine pilot has a significant advantage over a single-engine pilot, for he has the choice of stopping or continuing the takeoff. This would be similar to the choice facing a single-engine pilot who has suddenly lost slightly more than half of his takeoff power. In this situation, the single-engine pilot would be extremely reluctant to continue the takeoff if he had to climb over obstructions. However, if the failure occurred at an altitude as high or higher than surrounding obstructions, he would feel free to maneuver for a landing back at the airport.

Fortunately the airplane accelerates through this "area of decision" in just a few seconds. However, to make an intelligent decision in this type of an emergency, one must consider the field length, obstruction height, field elevation, air temperature, headwind, and the gross weight. The flight paths illustrated in the figure below indicate that the "area of decision" is bounded by: (1) the point at which 102 MPH is reached and (2) the point where the obstruction altitude is reached. An engine failure in this area requires an immediate decision. Beyond this area, the airplane, within the limitations of single-engine climb performance shown in Section VI, may be maneuvered to a landing back at the airport.

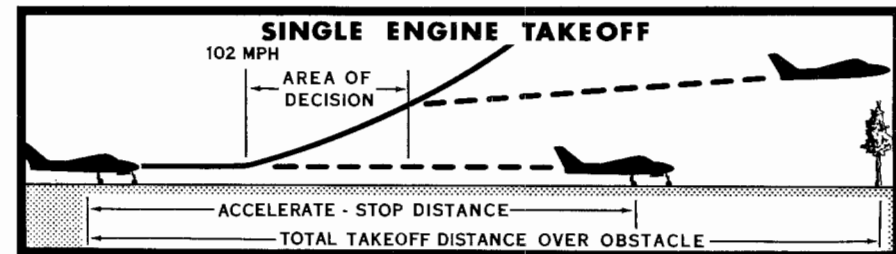

At sea level, with zero wind and 5100 pounds gross weight, the distance to accelerate to 102 MPH and stop is 3046 feet, while the total unobstructed area required to takeoff and climb over a 50-foot obstacle after an engine failure at 102 MPH is 3720 feet. This total distance over an obstacle can be reduced slightly under more favorable conditions of gross weight, headwind, or obstruction height. However, it is recommended that in most cases it would be better to discontinue the takeoff, since any slight mismanagement of the single-engine procedure would more than offset the small distance advantage offered by continuing the takeoff. The advantage of discontinuing the takeoff is even more obvious at higher alti-

tudes where the corresponding distances are 3411 and 4970 respectively, at 2500 feet. Still higher field elevations will cause the engine-out takeoff distance to lengthen disproportionately until an altitude is reached where a successful takeoff is improbable unless the airspeed and height above the runway at engine failure are great enough to allow a slight deceleration and altitude loss while the airplane is being prepared for a single-engine climb.

During single-engine takeoff procedures over an obstacle, only one condition presents any appreciable advantage, and this is headwind. A decrease of approximately 10% in ground distance required to clear a 50-foot obstacle can be gained for each 10 MPH of headwind. Excessive speed above best single-engine climb speed at engine failure is not nearly as advantageous as one might expect since deceleration is rapid and ground distance is used up quickly at higher speeds while the airplane is being cleaned up for climb. However, the extra speed is important for controllability.

The following facts should be used as a guide at the time of engine failure: (1) discontinuing a takeoff upon engine failure is advisable under most circumstances; (2) altitude is more valuable to safety after takeoff than is airspeed in excess of the best single-engine climb speed since excess airspeed is lost much more rapidly than is altitude; (3) climb or continued level flight at moderate altitude is improbable with the landing gear extended and the propeller windmilling; (4) in no case should the airspeed be allowed to fall below the engine-out best angle-of-climb speed, even though altitude is lost, since this speed will always provide a better chance of climb, or a smaller altitude loss, than any lesser speed. The engine-out best rate-of-climb speed will provide the best chance of climb or the least altitude loss, and is preferable unless there are obstructions which make a steep climb necessary.

Engine-out procedures should be practiced in anticipation of an emergency. This practice should be conducted at a safe altitude, with full power operation on both engines, and should be started at a safe speed of at least 120 MPH. As recovery ability is gained with practice, the starting speed may be lowered in small increments until the feel of the airplane in emergency conditions is well known. Practice should be continued until: (1) an instinctive corrective reaction is developed, and the corrective procedure is automatic; and (2), airspeed, altitude, and heading can be maintained easily while the airplane is being prepared for a climb. In order to simulate an engine failure, set both engines at full power operation, then at a chosen speed pull the mixture control of one engine into IDLE CUT-OFF, and proceed with single-engine emergency procedures.

EACH 100 HOURS.

SHIMMY DAMPENER -- Check and fill as required.

BRAKE MASTER CYLINDERS -- Check fluid level in reservoirs and fill as required through plugs on cylinder heads. Fill with hydraulic fluid (Red).

SUCTION RELIEF VALVE -- Remove breather and clean.

VACUUM SYSTEM FILTER -- Replace.

HEATER FUEL FILTER -- Remove and clean with unleaded gasoline.

OIL SEPARATORS -- Remove and clean.

PROPELLERS -- Lubricate.

EACH 500 HOURS.

SHOCK STRUTS -- Check and fill as required.

WHEEL BEARINGS -- Lubricate. Lubricate at first 100 hours and each 500 hours thereafter.

FLYABLE STORAGE

Flyable storage applies to all aircraft which will not be flown for an indefinite period but which are to be kept ready to fly with the least possible preparation. If the aircraft is to be stored temporarily, or indefinitely, refer to the Service Manual for proper storage procedures.

Aircraft which are not in daily flight should have the propellers rotated, by hand, five revolutions at least once each week. In damp climates and in storage areas where the daily temperature variation can cause condensation, propeller rotation should be accomplished more frequently. Rotating the propeller an odd number of revolutions, redistributes residual oil on the cylinder walls, crankshaft and gear surfaces and repositions the pistons in the cylinders, thus preventing corrosion. Rotate propellers as follows:

- (1) Throttles - IDLE.
- (2) Mixtures - IDLE CUT-OFF.

LUBRICATION AND SERVICING PROCEDURES.

Specific servicing information is provided here for items requiring daily attention. A Servicing Intervals Checklist is included to inform the pilot when to have other items checked and serviced.

DAILY.

FUEL TANK FILLERS -- Service after each flight. Keep full to retard condensation in tanks. Refer to Servicing Requirements table on inside back cover for fuel specification, grade, and quantity.

FUEL TANK SUMP DRAINS -- Drain before first flight each day and after each refueling.

FUEL STRAINER DRAINS -- Drain about two (2) ounces of fuel from each fuel strainer before first flight each day and after refueling.

OIL DIPSTICK AND FILLERS -- Check on preflight and add oil as necessary. Do not operate on less than 9 quarts. To minimize loss of oil through breather, fill to 10 quart level for normal flights of less than 3 hours. For extended flights, fill to 12 quarts. If optional oil filter is installed, 1 additional quart is required when the filter element is changed. Refer to Servicing Requirements table on inside back cover for oil specifications and grades.

SERVICING INTERVALS CHECKLIST.**EACH 50 HOURS.**

BATTERIES -- Check electrolyte level every 50 hours (at least every 30 days) or more often in hot weather.

ENGINE OIL AND OIL FILTER -- Change engine oil and replace filter element. If optional oil filter is not installed, change oil and clean screen every 25 hours. Change engine oil at least every four months even though less than 50 hours have been accumulated. Reduce periods for prolonged operation in dusty areas, cold climates, or when short flights and long idle periods result in sludging conditions.

INDUCTION AIR FILTER -- Service every 50 hours, more often under dusty conditions.

ENGINE-OUT DURING FLIGHT.

- (1) Determine Inoperative Engine (idle engine same side as idle foot).
- (2) Power -- Increase as required.
- (3) Mixture -- Adjust for altitude.

Before securing inoperative engine:

- (1) Fuel Flow -- Check, if deficient, position auxiliary fuel pump switch to ON.

NOTE

If fuel selector valve is in AUXILIARY TANK position, switch to MAIN TANK and feel for detent.

- (2) Fuel Quantity -- Check, and switch to opposite MAIN TANK if necessary.
- (3) Oil Pressure and Oil Temperature -- Check, shut down engine if oil pressure is low.
- (4) Magneto Switches -- Check.

If proper corrective action was taken, engine will restart. If it does not, secure as follows:

- (1) Auxiliary Fuel Pump -- OFF.
- (2) Mixture -- IDLE CUT-OFF.
- (3) Propeller -- FEATHER.
- (4) Turn off Generator, Magneto Switches and Fuel Selector Valve.
- (5) Turn off Sufficient Electrical Equipment to Eliminate a Negative Ammeter Reading.

ENGINE RESTARTS IN FLIGHT (After Feathering).

- (1) Fuel Selector Valve -- MAIN (feel for detent).
- (2) Throttle -- Advance until gear warning horn is silent.
- (3) Propeller -- HIGH RPM.

NOTE

With the optional propeller unfeathering system installed, the propeller will automatically windmill when the

propeller lever is moved to the HIGH RPM position. As propeller unfeathers and starts to windmill, decrease propeller lever to cruise position.

- (4) Mixture -- FULL RICH.
- (5) Magneto Switches -- ON.
- (6) Primer Switch -- Engage.
- (7) Starter Button -- Press.
- (8) Starter Button and Primer Switch -- Release when engine fires.
- (9) Power -- Increase slowly until cylinder head temperature reaches 200° F.

NOTE

If start is unsuccessful, turn magneto switches OFF, retard mixture to IDLE CUT-OFF, open throttle fully, and engage starter for several revolutions. Then repeat air start procedures.

MAXIMUM GLIDE.

In the event of a double engine-out condition, maximum gliding distance can be obtained by feathering both propellers, and maintaining approximately 112 MPH with the landing gear and wing flaps up. Refer to the Maximum Glide Diagram, Figure 3-1, for maximum glide data.

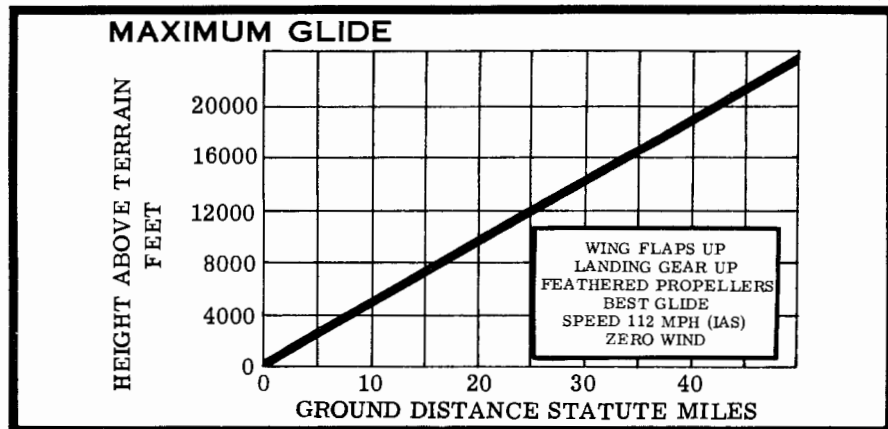

Figure 3-1.

AIRPLANE FILE.

There are miscellaneous data, information, and licenses that are a part of the airplane file. The following is a checklist for that file. In addition, a periodic check should be made of the latest Federal Aviation Regulations to insure that all data requirements are met.

A. To be displayed in the airplane at all times:

- (1) Aircraft Airworthiness Certificate (Form FAA-1362).
- (2) Aircraft Registration Certificate (Form FAA-500A).
- (3) Airplane Radio Station License (Form FCC-404, if transmitter installed).

B. To be carried in the airplane at all times:

- (1) Weight and Balance, and associated papers (latest copy of the Repair and Alteration Form, Form FAA-337, if applicable).
- (2) Aircraft Equipment List.
- (3) Pilot's Checklist.

C. To be made available upon request:

- (1) Airplane Log Book.
- (2) Engine Log Books.

NOTE

Cessna recommends that these items plus the Owner's Manual and the Cessna 310 Power Computer be carried in the airplane at all times.

Most of the items listed are required by the United States Federal Aviation Regulations. Since the regulations of other nations may require other documents and data, owners of exported aircraft should check with their own aviation officials to determine their individual requirements.

If you pick up the airplane at the factory, plan to take it to your Dealer reasonably soon after you take delivery of it. This will permit him to check it over and to make any minor adjustments that may appear necessary. Also, plan an inspection by your Dealer at 100 hours or 90 days, whichever comes first. This inspection is also performed for you by your Dealer at no charge. While these important inspections will be performed for you by any Cessna Dealer, in most cases you will prefer to have the Dealer from whom you purchased the airplane accomplish this work.

Federal Aviation Regulations require that all airplanes have a periodic (annual) inspection as prescribed by the administrator, and performed by a person designated by the administrator. In addition, 100-hour periodic inspections made by an "appropriately-rated mechanic" are required if the airplane is flown for hire. The Cessna Aircraft Company recommends the 100-hour periodic inspection for your airplane. The procedure for this 100-hour inspection has been carefully worked out by the factory and is followed by the Cessna Dealer Organization. The complete familiarity of the Cessna Dealer Organization with Cessna equipment and with factory-approved procedures provides the highest type of service possible at lower cost.

OWNER FOLLOWUP SYSTEM

Your Cessna Dealer has an Owner Followup System to notify you when he receives information that applies to your Cessna. In addition, if you wish, you may choose to receive similar notification directly from the Cessna Service Department. A subscription card is supplied in your airplane file for your use, should you choose to request this service. Your Cessna Dealer will be glad to supply you with details concerning these followup programs, and stands ready through his Service Department to supply you with fast, efficient, low cost service.

SINGLE-ENGINE APPROACH.

- (1) Approach at 112 MPH with excess altitude.
- (2) Landing Gear -- Extend when within gliding distance of field.
- (3) Wing Flaps -- As required when landing is assured.
- (4) Decrease speed below 102 MPH only if landing is a certainty.

SINGLE-ENGINE LANDING.

- (1) Approach at 112 MPH with excess altitude.
- (2) Delay extension of landing gear until within gliding distance of field.
- (3) Avoid use of flaps until landing is assured.
- (4) Decrease speed below 102 MPH only if landing is a certainty.

FORCED LANDING. (Precautionary Landing with Power).

- (1) Drag over selected field with flaps 15° and 102 MPH airspeed, noting type of terrain and obstructions.
- (2) Plan a wheels-down landing if surface is smooth and hard (pasture, frozen lake, etc.).
- (3) Execute a normal short-field landing, keeping nosewheel off ground until speed is decreased.
- (4) If terrain is rough or soft, plan a wheels-up landing as follows:
 - (a) Select a smooth grass-covered runway, if possible.
 - (b) Landing Gear Switch -- UP.
 - (c) Approach at 102 MPH with flaps down only 20°.
 - (d) All Switches Except Ignition Switches -- OFF.
 - (e) Unlatch Cabin Door Prior to Flare-out.

IMPORTANT

Be prepared for a mild tail buffet as the cabin door is opened.

- (f) Land in a slightly tail-low attitude.
- (g) Mixtures -- IDLE CUT-OFF (both engines).
- (h) Ignition Switches -- OFF.
- (i) Fuel Selector Valve Handles -- OFF.

NOTE

Airplane will slide straight ahead about 500 feet on smooth sod with very little damage.

FORCED LANDING (Complete Power Loss).

- (1) Mixtures -- IDLE CUT-OFF.
- (2) Feather propellers and rotate them to a HORIZONTAL position with starter, if time permits.
- (3) Fuel Selector Valve Handles -- OFF.
- (4) All Switches OFF except battery switch.
- (5) Approach at 115 MPH.
- (6) If field is smooth and hard, extend landing gear within gliding distance of field.
- (7) Extend flaps as necessary within gliding distance of field.
- (8) Battery Switch -- OFF.
- (9) Make a normal landing, keeping nosewheel off the ground as long as practical.
- (10) If terrain is rough or soft, plan a wheels-up landing as follows:
 - (a) Select a smooth grass-covered runway if possible.
 - (b) Landing Gear Switch -- UP.
 - (c) Approach at 102 MPH with flaps down only 20°.
 - (d) Battery Switch -- OFF.
 - (e) Unlatch cabin door prior to flare-out.
 - (f) Land in a slightly tail-low attitude.

SYSTEM EMERGENCY PROCEDURES.**FUEL SYSTEM.**

In the event of an engine-driven fuel pump failure, turn the auxiliary fuel pump switch (on the inoperative side) to ON. This pump will supply sufficient fuel for emergency takeoff, however, the mixture control must be reset.

IMPORTANT

If both an engine-driven fuel pump and an auxiliary fuel pump fail on the same side of the airplane, the failing engine cannot be supplied with fuel from the opposite MAIN tank since that auxiliary fuel pump will operate on

PROPELLER CARE.

Preflight inspection of propeller blades for nicks, and wiping them occasionally with an oily cloth to clean off grass and bug stains will assure long, trouble-free service. It is vital that small nicks on the propellers, particularly near the tips and on the leading edges, are dressed out as soon as possible since these nicks produce stress concentrations, and if ignored, may result in cracks. Never use an alkaline cleaner on the blades; remove grease and dirt with Stoddard solvent.

INTERIOR CARE.

To remove dust and loose dirt from the upholstery, headliner, and carpet, clean the interior regularly with a vacuum cleaner.

Blot up any spilled liquid promptly, with cleansing tissue or rags. Don't pat the spot; press the blotting material firmly and hold it for several seconds. Continue blotting until no more liquid is taken up. Scrape off sticky materials with a dull knife, then spot-clean the area.

Oily spots may be cleaned with household spot removers, used sparingly. Before using any solvent, read the instructions on the container and test it on an obscure place on the fabric to be cleaned. Never saturate the fabric with a volatile solvent; it may damage the padding and backing materials.

Soiled upholstery and carpet may be cleaned with foam-type detergent, used according to the manufacturer's instructions. To minimize wetting the fabric, keep the foam as dry as possible and remove it with a vacuum cleaner.

The plastic trim, instrument panel and control knobs need only be wiped with a damp cloth. Oil and grease on the control wheel and control knobs can be removed with a cloth moistened with kerosene. Volatile solvents, such as mentioned in paragraphs on care of the windshield, must never be used since they soften and craze the plastic.

INSPECTION SERVICE AND INSPECTION PERIODS.

With your airplane you will receive an Owner's Service Policy. Coupons attached to the policy entitle you to an initial inspection and the first 100-hour inspection at no charge. If you take delivery from your Dealer, he will perform the initial inspection before delivery of the airplane to you.

WINDOWS AND WINDSHIELDS.

The plastic windshield and windows should be kept clean and waxed at all times. To prevent scratches and crazing, wash them carefully with plenty of soap and water, using the palm of the hand to feel and dislodge dirt and mud. A soft cloth, chamois or sponge may be used, but only to carry water to the surface. Rinse thoroughly, then dry with a clean, moist chamois. Rubbing the surface of the plastic with a dry cloth builds up an electrostatic charge which attracts dust particles in the air. Wiping with a moist chamois will remove both the dust and this charge.

Remove oil and grease with a cloth moistened with kerosene. Never use gasoline, benzine, alcohol, acetone, carbon tetrachloride, fire extinguisher or anti-ice fluid, lacquer thinner or glass cleaner. These materials will soften the plastic and may cause it to craze.

After removing dirt and grease, if the surface is not badly scratched, it should be waxed with a good grade of commercial wax. The wax will fill in minor scratches and help prevent further scratching. Apply a thin, even coat of wax and bring it to a high polish by rubbing lightly with a clean, dry, soft flannel cloth. Do not use a power buffer; the heat generated by the buffing pad may soften the plastic.

Do not use a canvas cover on the windshield unless freezing rain or sleet is anticipated. Canvas covers may scratch the plastic surface.

PAINTED SURFACES.

The painted exterior surfaces of your new Cessna require an initial curing period which may be as long as 90 days after the finish is applied. During this curing period some precautions should be taken to avoid damaging the finish or interfering with the curing process. The finish should be cleaned only by washing with clean water and mild soap, followed by a rinse water and drying with cloths or a chamois. Do not use polish or wax, which would exclude air from the surface, during this 90-day curing period. Do not rub or buff the finish and avoid flying through rain, hail, or sleet.

Once the finish has cured completely, it may be waxed with a good automotive wax. A heavier coating of wax on the leading edges of the wings and tail and on the front engine nose cap and propeller spinner will help reduce the abrasion encountered in these areas.

the low pressure setting as long as the corresponding engine fuel pump is operative.

LANDING GEAR SYSTEM.

MANUAL EXTENSION.

When the landing gear will not extend electrically, it may be extended manually in accordance with the following steps:

- (1) Before proceeding manually, check landing gear circuit breakers with landing gear switch DOWN. If circuit breakers are tripped, allow 3 minutes for them to cool before resetting.
- (2) If circuit breaker is not tripped, place landing gear switch in the OFF (middle) position.
- (3) Crank gear down approximately two turns past the point where the gear-down indicator light (green) comes on (approximately 60 turns of the handcrank).

NOTE

During manual extension of the gear, never release the handcrank to let it turn freely of its own accord.

- (4) Check gear-down indicator light and gear warning horn with throttle retarded.
- (5) Stow handcrank.

NOTE

The landing gear should never be retracted with the manual system, as undue loads will be imposed and cause excessive wear on the cranking mechanism.

LANDING EMERGENCIES.

LANDING WITH FLAT MAIN GEAR TIRE.

If a blowout occurred during takeoff, and the defective main gear tire is identified, proceed as follows:

- (1) Landing Gear Switch -- UP.
- (2) Fuel Selector Valve Handles -- Turn to main tank on same side as defective tire and feel for detent. Proceed to destination, to reduce fuel load.

NOTE

Fuel should be used from this tank first to lighten the load on this wing prior to attempting a landing, if in-flight time permits. However, an adequate supply of fuel should be left in this tank so that it may be used during landing.

- (3) Fuel Selectors - Left Engine -- LEFT MAIN. (feel for detent).
Right Engine -- RIGHT MAIN. (feel for detent).
- (4) Select a runway with a crosswind from the side opposite the defective tire if a crosswind landing is required.
- (5) Landing Gear Switch -- DOWN (below 140 MPH).
- (6) Check landing gear down indicator light (green) for indication.
- (7) Flaps Switch -- DOWN. Fully extend flaps to 35°.
- (8) In approach, align airplane with edge of runway opposite the defective tire, allowing room for a mild turn in the landing roll.
- (9) Land slightly wing-low on side of inflated tire and lower nose-wheel to ground immediately, for positive steering.
- (10) Use full aileron in landing roll, to lighten load on defective tire.
- (11) Apply brake only on the inflated tire, to minimize landing roll and maintain directional control.
- (12) Stop airplane to avoid further tire and wheel damage, unless active runway must be cleared for other traffic.

LANDING WITH FLAT NOSE GEAR TIRE.

If a blowout occurred on the nose gear tire during take-off, prepare for a landing as follows:

- (1) Landing Gear Switch -- Leave DOWN.

IMPORTANT

Do not attempt to retract the landing gear if a nose gear tire blowout occurs. The nose gear tire may be distorted enough to bind the nosewheel strut within the wheel well and prevent later gear extension.

- (2) Move disposable load to baggage area and passengers to available rear seat space.
- (3) Flaps Switch -- DOWN. Extend flaps from 0° to 20°, as desired.
- (4) Land in a nose-high attitude with or without power.
- (5) Maintain back pressure on control wheel to hold nosewheel off the ground in landing roll.
- (6) Use minimum braking in landing roll.



SECTION V

CARE OF THE AIRPLANE

If your airplane is to retain that new-plane performance and dependability, certain inspection and maintenance requirements must be followed. It is wise to follow a planned schedule of lubrication and preventive maintenance based on climatic and flying conditions encountered in your locality.

Keep in touch with your Cessna Dealer, and take advantage of his knowledge and experience. He knows your airplane and how to maintain it. He will remind you when lubrications and oil changes are necessary, and about other seasonal and periodic services.

GROUND HANDLING.

The airplane is most easily and safely maneuvered during ground handling by a tow-bar attached to the nosewheel.

NOTE

When using the tow-bar, never exceed the nosewheel turning radius of 55° either side of center, or damage to the gear will result. Never use a tug for towing by nose gear. Refer to Cessna Model 310 Service Manual for towing procedures.

MOORING YOUR AIRPLANE.

Proper tie-down procedure is your best precaution against damage to your parked airplane by gusty or strong winds. To tie-down your airplane securely, proceed as follows:

- (1) Set the parking brake and install control wheel lock.
- (2) Tie strong ropes or chains (700 pounds tensile strength) to wing tie-down fittings.
- (3) Caster the nosewheel to the extreme left or right positions.
- (4) Tie a strong rope or chain (700 pounds tensile strength) to the tail skid.
- (5) Recommend installation of pitot tube cover.

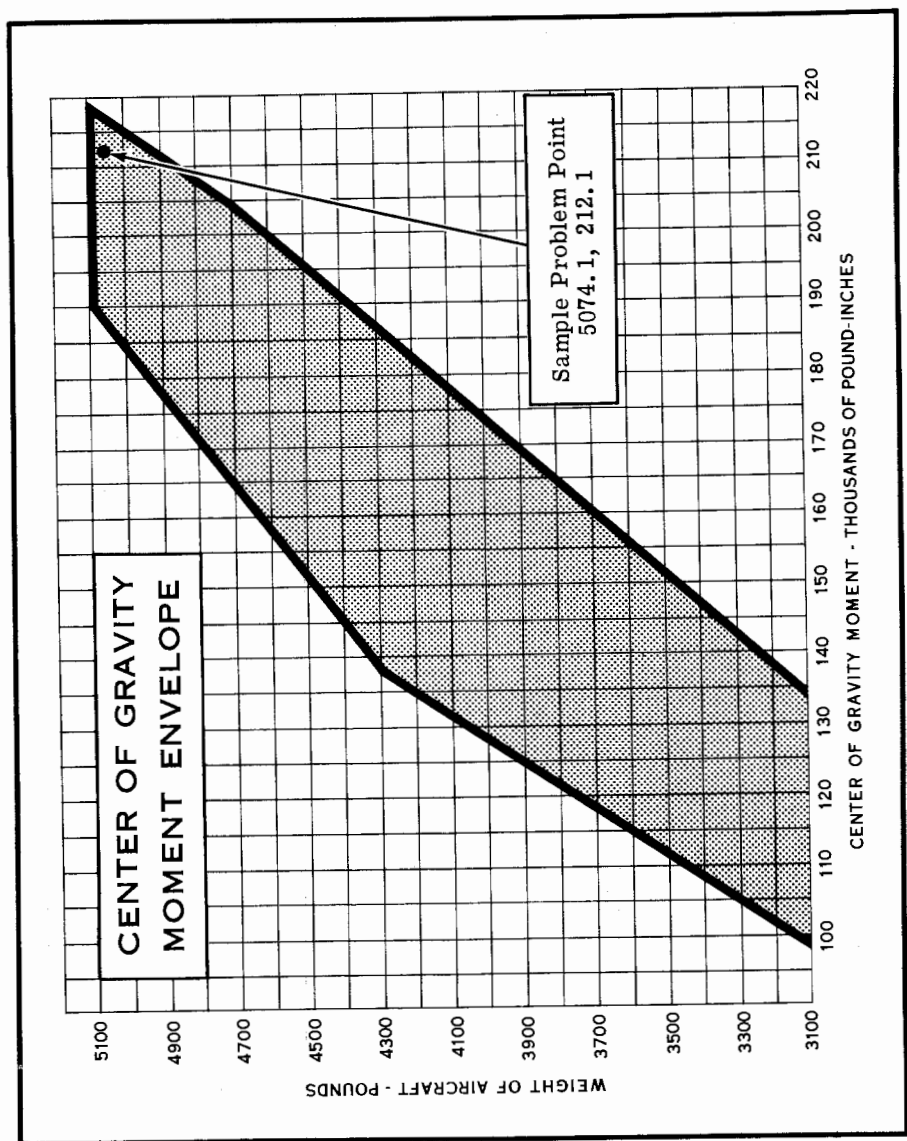

Figure 4-3.

- (7) Throttles -- Retard in landing roll.
- (8) As landing roll speed diminishes, hold control wheel fully aft until airplane is stopped.
- (9) Avoid further tire damage by holding additional taxi to a minimum.

LANDING WITH DEFECTIVE MAIN GEAR.

Reduce the fuel load in the tank on the side of the faulty main gear as explained in paragraph LANDING WITH FLAT MAIN GEAR TIRE. When fuel load is reduced, prepare to land as follows:

- (1) Fuel Selectors - Left Engine -- LEFT MAIN (feel for detent).
Right Engine -- RIGHT MAIN (feel for detent).
- (2) Select a wide, hard surface runway, or if necessary a wide sod runway. Select a runway with crosswind from the side opposite the defective landing gear, if a crosswind landing is necessary.
- (3) Landing Gear Switch -- DOWN.
- (4) Flaps Switch -- DOWN. Extend flaps to 30°.
- (5) In approach, align airplane with edge of runway opposite the defective landing gear, allowing room for a ground-loop in landing roll.
- (6) Battery Switch -- OFF.
- (7) Land slightly wing-low toward the operative landing gear and lower the nosewheel immediately, for positive steering.
- (8) Mixture Levers -- IDLE CUT-OFF (both engines).
- (9) Use full aileron in landing roll to lighten the load on the defective landing gear.
- (10) Apply brake only on the operative landing gear to maintain directional control and minimize the landing roll.
- (11) Fuel Selector Valve Handles -- OFF.
- (12) Evacuate the airplane as soon as it stops.

LANDING WITH DEFECTIVE NOSE GEAR.

Sod Runway— Main Gear Retracted.

This procedure will produce a minimum amount of airplane damage on smooth runways. This procedure is also recommended for short, rough, or uncertain field conditions where passenger safety, rather than minimum airplane damage, is the prime consideration.

- (1) Select a smooth grass-covered runway, if possible.
- (2) Landing Gear Switch -- UP.
- (3) Approach at 102 MPH with flaps down only 20°.
- (4) All Switches except Ignition Switches -- OFF.
- (5) Unlatch cabin door prior to flare-out.
- (6) Land in a slightly tail-low attitude.
- (7) Mixture Levers -- IDLE CUT-OFF (both engines).
- (8) Ignition Switches -- OFF.
- (9) Fuel Selector Valve Handles -- OFF.

Smooth Hard Surface Runway — Main Gear Extended.

- (1) Move disposable load to baggage area, and passengers to available rear seat space.
- (2) Select a smooth hard surface runway.
- (3) Landing Gear Switch -- DOWN.
- (4) Approach at 102 MPH with flaps down 20°.
- (5) All Switches except Ignition Switches -- OFF.
- (6) Land in a slightly tail-low attitude.
- (7) Mixture Levers -- IDLE CUT-OFF (both engines).
- (8) Ignition Switches -- OFF.
- (9) Hold nose off throughout ground roll - Lower gently as speed dissipates.

DITCHING.

- (1) Plan approach into wind if winds are high and seas are heavy. With heavy swells and light wind, land parallel to swells, being careful not to allow wing tip to hit first.
- (2) Approach with landing gear retracted, flaps 35°, and enough power to maintain approximately 200 ft/min. rate-of-descent at approximately 108 MPH at 4600 pounds gross weight.
- (3) Maintain a continuous descent until touchdown, to avoid flaring and touching down tail-first, pitching forward sharply, and decelerating rapidly. Strive for initial contact at fuselage area below rear cabin section (point of maximum longitudinal curvature of fuselage).

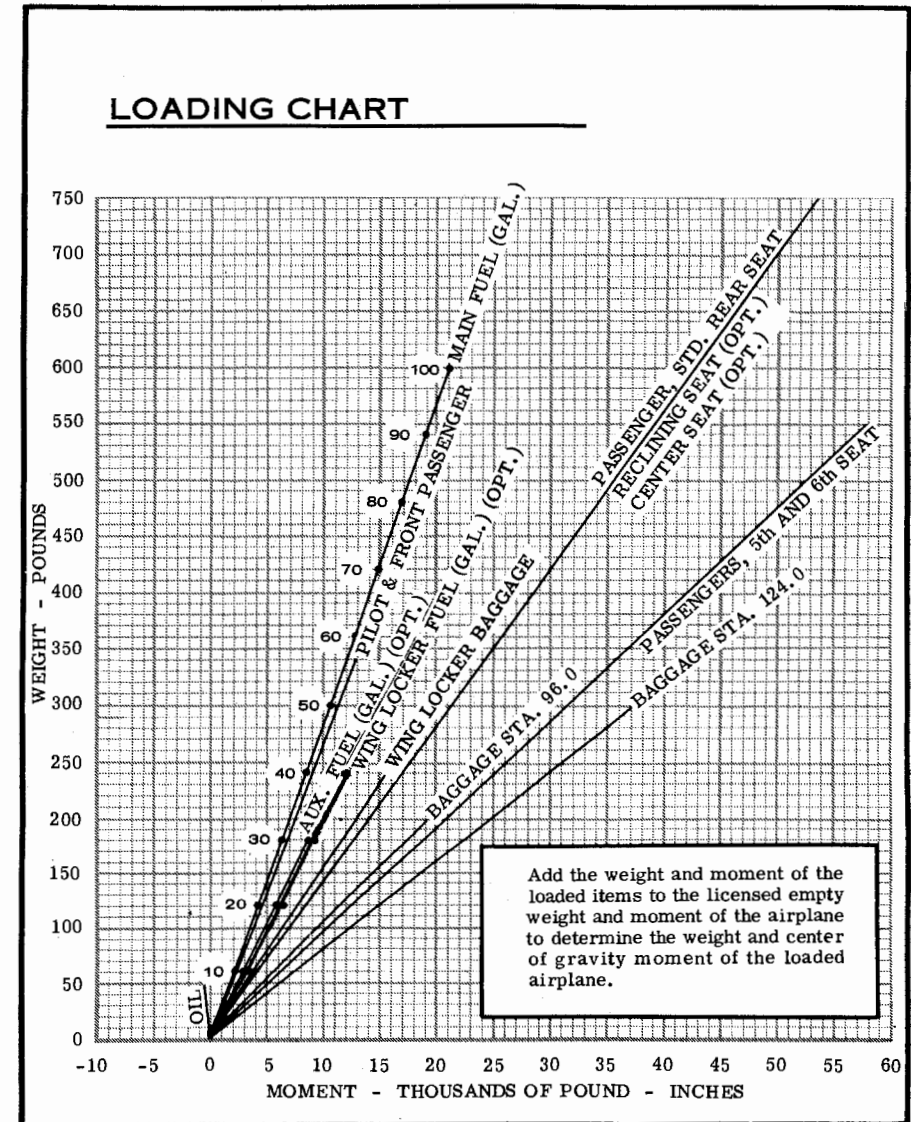

Figure 4-2.

SAMPLE PROBLEM	Sample Aircraft		Sample Aircraft	
	Weight (lbs)	Moment (lb-ins.) /1000		Moment (lb-ins.) /1000
1. Licensed Empty Weight (Sample Problem).....	3375.1	123.3		
2. Oil-W/Opt./Oil Filter *(26 Qts. x 1.875 lb/qt.)	49.0	-0.2	49.0	-0.2
3. Pilot and Passenger	340.0	12.6		
4. Rear Passengers (Standard Seating)	510.0	36.2		
5. Fuel (gals. x 6 lbs./gal.) Main Tanks (100 gals.)	600	21.0		
Auxiliary Tanks				
Wing Locker Tanks				
6. Baggage (Sta. 96.0)..... (124.0)	200.0	19.2		
(Wing Lockers)				
7. Total Aircraft Weight (Loaded)	5074.1	212.1		
8. Locate this point (5074.1 at 212.1) on Figure 4-3 and since this point falls within the envelope, the loading is acceptable.				
*Note: Normally full oil may be assumed for all flights.				

Figure 4-1.



SECTION IV OPERATING LIMITATIONS

OPERATIONS AUTHORIZED.

Your Cessna with standard equipment, as certificated under FAA Type Certificate No. 3A10, is approved for day and night operation under VFR conditions.

MANEUVERS-NORMAL CATEGORY.

The aircraft exceeds the requirements of the Federal Aviation Regulations, Part 3, set forth by the United States Government for airworthiness. Spins and aerobatic maneuvers are not permitted in normal category aircraft in compliance with these regulations. In connection with the foregoing, the following gross weight and flight load factors apply:

Maximum Take-Off Weight	5100 lbs
Maximum Landing Weight	5100 lbs
*Flight Load Factor		
Flaps UP	+3.8 -1.52
Flaps DOWN	+2.0

*The design load factors are 150% of the above and in all cases the structure exceeds design loads.

Your airplane must be operated in accordance with all FAA approved markings, placards, and checklists in the airplane. If there is any information in this section that contradicts the FAA approved markings, placards, and checklists it is to be disregarded.

AIRSPPEED LIMITATIONS (CAS).

Maximum Structural Cruising Speed		
Level Flight or Climb	210 MPH
Maximum Speed		
Flaps Extended 15°	160 MPH
Flaps Extended 15° - 35°	140 MPH
Gear Extended	140 MPH

Pilot's Window Open 130 MPH
 *Maximum Maneuvering Speed 170 MPH

*The maximum speed at which you can use abrupt control travel.

AIRPEED INDICATOR INSTRUMENT MARKINGS.

The following is a list of the certificated calibrated airspeed (CAS) limitations for the airplane.

Never Exceed (glide or dive, smooth air). 254 MPH (red line)
 Caution Range 210-254 MPH (yellow arc)
 Normal Operating Range 84-210 MPH (green arc)
 Flap Operating Range (0° - 35°) 77-140 MPH (white arc)

ENGINE OPERATION LIMITATIONS.

Maximum Power and Speed 260 BHP at 2625 RPM
 (for all operations)

ENGINE INSTRUMENT MARKINGS.

OIL TEMPERATURE GAGES.

Normal Operating Range 80° to 225° F (green arc)
 Maximum Temperature 225° F (red line)

OIL PRESSURE GAGES.

Idling Pressure 10 PSI (red line)
 Normal Operating Range 30 to 60 PSI (green arc)
 Maximum Pressure 100 PSI (red line)

CYLINDER HEAD TEMPERATURE.

Normal Operating Range 200° to 460° F (green arc)
 Maximum Temperature 460° F (red line)

MANIFOLD PRESSURE.

Normal Operating Range 15 to 24 in. Hg. (green arc)

TACHOMETER.

Normal Operating Range 2100 to 2450 RPM (green arc)
 Maximum Engine Rated Speed 2625 RPM (red line)

FUEL FLOW GAGE.

Normal Operating Range 0 to 23 GPH (green arc)
 Minimum and Maximum Fuel Flows 0 to 23 GPH (red line)
 1.5 and 17.5 PSI (red line)

WING LOCKERS.

The wing lockers are intended primarily for low density items such as luggage and briefcases. The floor of the wing lockers, in particular, is primary structure, therefore, care should be exercised during loading and unloading to prevent damage. When loading high density objects, insure that adequate protection is available to prevent damage to any airplane primary structure.

WEIGHT AND BALANCE.

The following information will enable you to operate your Cessna within the prescribed weight and center of gravity limitations. To figure the weight and balance for your particular airplane, use figures 4-1, 4-2, and 4-3 as follows.

Take the licensed Empty Weight and Moment/1000 from the Weight and Balance Data sheet, plus any changes noted on forms FAA-337, carried in your airplane, and write them down in the proper columns of figure 4-1. Using figure 4-2, determine the moment/1000 of each item to be carried. Total the weights and moments/1000 and use figure 4-3 to determine whether the point falls within the envelope and if the loading is acceptable.